

# Energy Delivery Service Guide

*Connecting to Gainesville Regional Utilities*



More than Energy

May 6, 2025

Volume 1, Issue 63



A reference guide  
for planning and designing  
electric and gas installations  
to be served by GRU.

- ◆ Architects
- ◆ Contractors
- ◆ Customers
- ◆ Developers
- ◆ Electricians
- ◆ Engineers

Supersedes Energy Delivery Service Guide dated April 2, 2025.

## **INTRODUCTION**

Our goal is to provide every customer with safe, reliable and competitively priced electric and gas service. Achieving this goal means working closely with each customer to build efficient electrical and gas facilities. The Energy Delivery Service Guide has been written to inform you about our requirements for installing, maintaining and replacing electric and gas service and metering equipment.

The Energy Delivery Service Guide is for our customers who may be planning, designing and building facilities requiring electric and/or gas service. This guide is also for those customers who are planning changes to their existing electric and/or gas service. We encourage you to familiarize yourself with the service guide contents.

When you follow this guide, we are better able to provide the best possible service.

Every effort has been made to ensure that the requirements contained in the Energy Delivery Service Guide are up-to-date. However, your needs, changing codes and technology may require us to revise this guide.

Our staff stands ready to provide any additional information you may need. A calling list is printed on the back of this page for your convenience.

**We welcome your comments and suggestions.**

Please address them to:  
Gainesville Regional Utilities  
Manager of Energy Delivery Engineering  
P.O. Box 147117, Station E2-C  
Gainesville, Florida 32614-7117

Note: Exceptions –

Any deviations from the Electric guidelines stated here-in must be approved by both GRU's Energy Delivery Engineering Manager and GRU's T&D Construction Manager.

**THIS MANUAL IS NOW ON THE GRU WEB SITE SEE PAGE 6 FOR INSTRUCTIONS.**

This Energy Delivery Service Guide, dated May 6, 2025 supersedes the Energy Delivery Service Guide, dated September 15, 2011, Volume 1, Issue 1 as provided for in the Gainesville Code, Section 27-36

**Gainesville Regional Utilities  
Calling Guide**

**New Service Division (352) 393-1413 (local), or (800) 818-3436 (statewide)**

**Contact the New Service Division for general assistance and information on new services, including information about electric, gas, water and waste water utility services, applications, fees and related concerns.**

**Energy Delivery Engineering Division (352) 393-1500**

**Contact the Energy Delivery Engineering Division for information on the availability of service, service voltage characteristics and construction planning and for assistance with extensions of service and additions or modifications to existing services.**

**Gas and Electric Measurement (GEM) Department (352) 393-1505**

**Contact the GEM Division for information on specific gas and electric metering requirements, revenue meters and related equipment when it is furnished by GRU in accordance with this policy. This division also assists customers in determining the acceptability of customer furnished electric metering equipment and with questions regarding gas pressure, gas volume, and gas regulating requirements.**

**Gas Emergency Trouble Reporting (352) 334-2550 or 911**

**Contact for gas emergencies.**

**Transmission and Distribution Division (352) 393-1551**

**Contact the Transmission & Distribution Division for information on the following: construction scheduling; for information on required inspections of customer installed utility facilities**

**Electric System Control Center (352) 334-2871**

**Contact the Electric System Control Center to report trouble and to inquire about service quality concerns.**

**City of Gainesville, Building Inspection Department (352) 334-5050**

**Contact for information on building permits and inspections, within the City of Gainesville.**

**Alachua County, Building Department (352) 374-5240**

**Contact for information on building permits and inspections within the unincorporated area of Alachua County.**



## TABLE OF CONTENTS

INTRODUCTION	1
CALLING GUIDE	2
TABLE OF CONTENTS	3&4
How to Look Up the “Energy Delivery Service Guides” on the GRU Web Site	5&6
<b>Section 1: GENERAL INFORMATION</b>	<b>7</b>
1.1 Service Type and Availability	
1.2 Applying for Service	
1.3 Temporary Service and Relocations of Temporary Service	
1.4 Point of Service	
1.5 Electric and Gas Service Provisions	
1.6 Relocation, Modification or Removal of Existing GRU Facilities Alterations & Additions	
1.7 Use of Service	
1.8 Service Quality	
1.9 Connecting Safely	
1.10 Code Compliance and Inspections	
1.11 Access to Private Property (Easement and Clearance)	
1.12 Typical Drawings	
1.13 Vegetation Management	
<b>Section 2: SERVICES AT SECONDARY VOLTAGES</b>	<b>23</b>
2.1 General	
2.2 Secondary Service Voltages	
2.3 Overhead Secondary Service (Permanent)	
2.4 Underground Secondary Service (Permanent)	
2.5 Temporary Secondary Service	
<b>Section 3: METERING AT SECONDARY VOLTAGES</b>	<b>33</b>
3.1 Approval of Metering Equipment Installations	
3.2 Responsibility for Furnishing Metering Equipment	
3.3 General Requirements for Installation of Metering Equipment	
3.4 Mounting Requirements for Metering Equipment	
3.5 Locating Metering Equipment	
3.6 Customer Furnished Meter Sockets	
3.7 Customer Furnished Multiple Position Metering	
3.8 Self-Contained and Instrument Transformer Metering	
3.9 Metering Installations in Mobile Home Parks	
3.95 Metering Equipment Mounted on Manufactured Homes	

<u>Section 4: REQUIREMENTS FOR UNDERGROUND SERVICE IN NEW DEVELOPMENTS</u>		62
4.1	General Requirements	
4.2	Responsibility for Furnishing and Installing Underground Infrastructure	
<u>Section 5: PRIMARY VOLTAGE AND SPECIAL SERVICE CONDITIONS</u>		70
5.1	Installations at Primary Distribution Voltages	
5.2	Standby and Parallel Generators	
5.3	Motors	
5.4	Operating Characteristics	
5.5	Transformer Vault Requirements	
<u>Section 6: LIGHTING SERVICE</u>		79
6.1	Service Categories	
6.2	Requesting Public Lighting Service	
6.3	Requesting Rental Lighting Service	
6.4	Requirements for Public Lighting Service	
6.5	Requirements for Rental Lighting Service	
6.6	Information for Developers/Contractors Requesting Lighting	
6.7	Maintenance and Repair	
<u>Section 7: NATURAL GAS SERVICE</u>		83
7.1	General	
7.2	Typical Gas Service Installation	
7.3	Gas Meter Location	
7.4	Inside Gas Piping	
<u>Section 8: SOLAR ELECTRIC PHOTOVOLTAIC (PV) Net Energy Metering (NEM)</u>		91
8.1	General Information	
8.2	Procedures	
8.3	Construction	
8.4	NET-Metering PV Installation Requirements	
8.5	Example of Site Plans Diagram	
<u>GLOSSARY</u>		103-106
<u>INDEX</u>		107
<u>SERVICE AREA MAP</u>		109

**How to Look Up the  
Energy Delivery Service Guides  
on The GRU Web Site**

The Gainesville Regional Utilities (GRU) Energy Delivery Service Guide and Appendixes, issued by Energy Delivery Standards, may be viewed and printed from the following Web Site:

**<http://www.gru.com>**

Below are the steps for access the GRU Web Site and the Energy Delivery Service Guides.

**Steps To View Web Site from you browser:**

- Step 1) Type in: [www.gru.com](http://www.gru.com) - this is the GRU Web Site
- Step 2) Go to the Title Bar drop down menu "Work with GRU" - select
- Step 3) Under "Work with GRU Links" (left hand side of the web page) choose "Construction & Development", and then choose "Energy Delivery Services Guide" this will take you to a new page.



Work With GRU

Menu
<a href="#">Partnering Contractor Programs</a>
<a href="#">Purchasing-</a>
<a href="#">Construction &amp; Development-</a>
<a href="#">Real Estate-</a>

## Business opportunities with GRU

GRU believes in maximizing its business partnership opportunities. From seeking qualified vendors for equipment and materials to developing partnering contractor opportunities with our energy-efficiency programs, we want to make it easier to do business with us.

### Partnering Contractor Programs

Opportunities for electricians, plumbers, HVAC contractors and other installers to expand their customer base through our energy-efficiency programs

**How to Look Up the  
Energy Delivery Service Guides  
on The GRU Web Site, cont.**

- Step 4) At the bottom of this page are the links to the “Energy Delivery Service Guide” documents.
- \* Step 5) “Energy Delivery Service Guide (pdf)” will open up the text document.
- \* Step 6) "Energy Delivery Service Guide Appendixes (pdf)" will open up the document that contains materials, construction drawings and other information.
- \* Note: If the file does not appear and no error message is indicated refresh your screen using the F5 key and/or **check to make sure your "Pop-Up" blocker is disabled.** The pages at this location are in PDF (Acrobat Reader) file format and can be printed for your files.

ABOUT GRU   WORK WITH GRU   CONTACT US   PAY MY BILL   Q

**GRU**  
More than Energy

FOR MY HOME   FOR MY BUSINESS   ENVIRONMENT & COMMUNITY

# Energy Delivery Service Guide

[Pay My Bill »](#)   [Report An Outage »](#)   [Start, Stop, Move »](#)

Work With GRU » Construction & Development » Energy Delivery Service Guide

Menu
<a href="#">Partnering Contractor Programs</a>
<a href="#">Purchasing</a> ▾
<a href="#">Construction &amp; Development</a> ▾
<a href="#">Real Estate</a> ▾
<a href="#">New Services</a>
<a href="#">Careers with GRU</a>

## Electric, gas service and metering equipment requirements

Learn more about the requirements for installing, maintaining and replacing electric and gas service and metering equipment.

Our goal is to provide every customer with safe, reliable and competitively priced electric and gas service. Achieving this goal means working closely with each customer to build efficient electrical and gas facilities.

The Energy Delivery Service Guide for our customers who are:

- Planning, designing and building facilities requiring electric or gas service
- Planning changes to their existing electric or gas service

[Energy Delivery Service Guide \(pdf\)](#)

[Energy Delivery Service Guide Appendixes \(pdf\)](#)

## **Section 1: GENERAL INFORMATION**

### **1.1 Service Types and Availability**

- 1) The Electric Engineering Department and the Gas Engineering Department (Dept.) provide information about the availability of electrical and gas service for a specific location. They will confirm the availability of service, point of delivery and service requirements of all services. To assure prompt service, customers are encouraged to contact the Electric and Gas Engineering Departments.
- 2) Service voltage and requirements offered depend on the size and type of the customer's electrical load and its location on the electric distribution system. Contact the Electric Engineering Dept. for a final determination of service requirements prior to ordering or purchasing electrical equipment. GRU will confirm all service requirements before construction has begun.
- 3) Services described in this guide are those most commonly offered. Customers are encouraged to contact Electric Engineering Dept. about special service needs. Electric and Gas Engineering staff is available to consult with customers about electrical and gas equipment and special situations not covered in this guide.
- 4) In accordance with the "City of Gainesville Code of Ordinances", Section 30 – 8.2 (C) Underground Utilities, Design Standards all new Electric Facilities shall be built underground.

### **1.2 Applying for Service**

- 1) GRU provides electric and gas service to any customer in the corporate limits of the City of Gainesville and within the bounds of its territorial agreement(s) in the unincorporated areas of Alachua County, Florida, subject to the following conditions:
  - (a) An application for service has been completed.
  - (b) All applicable deposits and/or fees have been paid.
  - (c) All required permits and/or certificates of inspection have been obtained from the local inspection authorities.
  - (d) All requirements of any applicable ordinances have been met.

### **1.3 Electric Temporary Service and Relocations of Temporary Service**

- 1) To assure prompt service, applications for temporary service should be made well in advance of the required service date. Temporary service locations should be clearly marked with the lot number and street address shown on the application. Contact Electric Engineering Dept. to schedule an on-site meeting to determine point of interconnection.
- 2) **TEMPORARY SERVICE INSTALLATIONS SHALL BE CONSTRUCTED WITH THE SAME CARE AS PERMANENT SERVICE INSTALLATIONS.** Overhead temporary service will ordinarily be located within 80 feet of an existing pole. Temporary service locations served from underground distribution should be located within 4 feet of a padmount transformer, UD Service Enclosure or other location designated by a qualified employee. See drawings on pages 31 and 32.



- 3) A temporary service drop or a temporary service lateral conforming to paragraph 1.3 (2) above will be provided for a fee. City of Gainesville Code of Ordinances, Section 27-25 requires the customer to pay any other costs of installing and/or removing temporary electric services. All fees shall be paid in advance of any work.
- 4) The cost of customer initiated relocation of any temporary service conductors and related equipment will be charged to the customer. All costs shall be paid in advance of any work.

#### **1.4 Point of Service**

- 1) GRU will connect only one Electric service drop or service lateral of the same voltage to a building or other structure.
- 2) Meters for multiple occupancy buildings shall be placed in one location on each building, unless a qualified Metering Dept. employee, in consultation with the customer, determines that rendering service in more than one location will result in the most economical design of the utility's electric distribution system.

#### **1.5 Electric and Gas Service Provisions**

- 1) A customer desiring service should contact the Engineering Division and apply well in advance of the required service date.
- 2) The customer is responsible for providing the location of the new service including the service address (911 address), street number and street name if available.
- 3) Electric customers must provide the Engineering Division with a detailed site plan, electrical riser diagram, a panel schedule showing all electrical loads including heating and air conditioning, and the building loads calculation per National Electrical Code (NEC). The customer is responsible for the accuracy of electrical load information and will be charged for any cost incurred by GRU that results from inaccurate and/or omitted load data.
- 4) Gas customer must provide the Gas Engineering Dept. total connected gas load and pressure requirements. The customer is responsible for the accuracy gas load information and will be charged for any cost incurred by GRU that results from inaccurate and/or omitted load data.
- 5) Text moved to Section 1.6, 5 page 10.
- 6) Should the estimated revenues be inadequate to cover the cost of the new proposed development or customer service, the customer or developer will be required to make a Contribution In Aid of Construction (CIAC). Refer to Section 27-34, 'City of Gainesville Code of Ordinances'.

## **1.6 Relocation, Modification or Removal of Existing GRU Facilities**

- 1) Customers should notify the Engineering Division in advance of any significant modifications, additions, or deletions that will alter the electrical or gas loads. This notice will permit the installation of electric and/or gas service and metering equipment that are properly designed to serve the customer's actual load. Existing service and metering equipment may not be adequate or safe when modifications or additions affect GRU's electric and gas system. Refer to Section 27-34, "City of Gainesville Code of Ordinances".
- 2) The cost of customer initiated relocations, modifications, removals or conversions of overhead to underground utility facilities will be charged to the customer. All costs shall be paid in advance of any work. See drawing on page 14 this Section for residential costs. Refer to Section 27-33, of the "City of Gainesville Code of Ordinances".
- 3) Any proposed development in conflict with existing GRU electric facilities must be identified well in advance of construction to insure an orderly adjustment or relocation of the facilities in question. The developer will be responsible for all costs associated with the modifications required. GRU reserves the right to maintain its facilities in place until these conditions have been satisfied and must be given sufficient time to construct or rebuild its facilities. Refer to Section 27-33, of the "City of Gainesville Code of Ordinances".
- 4) All costs of relocating, removing or modifying overhead to underground utility facilities that are attributable to city DEPARTMENT OF PUBLIC WORKS initiated renewal or reconstruction projects shall be borne by either the CITY UTILITY or THE CITY OF GAINESVILLE PUBLIC WORKS DEPARTMENT. Refer to the "Utility Accommodations Manual" (aka UAM).
- 5) GRU will construct any required extension, improvement or modification of its distribution facilities, that is required to render underground service to a customer or a development, provided that the customer or developer furnishes and installs all (electric conduit, concrete equipment foundations and related civil infrastructure and any CIAC required. Refer to Section 27-34, of the "City of Gainesville Code of Ordinances". The customer or developer shall furnish only those approved materials listed in the Energy Delivery Guide Appendices. Refer to Section 27-35, of the "City of Gainesville Code of Ordinances". All materials must be inspected prior to installation to confirm they meet standards.
- 6) Service conductors, connections and all other components of GRU's electric and gas distribution system shall be installed, relocated, adjusted, modified, disconnected, or removed only by qualified employees of GRU or its authorized agent(s).

## **1.7 Use of Service**

- 1) GRU's electric distribution system and the customer's wiring system must be compatible. To assure compatibility, customers should adhere to the following practices:
  - (a) Use overcurrent protection devices in accordance with the National Electrical Code.
  - (b) Use equipment and service only in a way that does not disturb GRU's service to other customers.

- 2) When designing a wiring system, the customer should always attempt to connect and balance loads so that the difference in current (amperes) between phases will be 15% or less, as measured from the most heavily loaded phase to the least loaded phase as reflected on the panel board schedule submitted.
- 3) Electric energy purchased from GRU under the residential, general, large power, or transmission service rates shall be used for the customer's direct benefit only. The resale of electric prohibited. Refer to Section 27-22, of the "City of Gainesville Code of Ordinances".
- 4) GRU does not install or maintain electric sub metering applications. Energy demand data from a sub meter will not be used for GRU electric billing purposes.

### **1.8 Service Quality**

- 1) GRU strives to give its customers the highest quality electric service. However, normal system operations and unavoidable system disturbances may cause problems with certain types of sensitive equipment, most notably computers. The Electric Engineering Dept. will provide assistance to any customer with electrical equipment problems.
- 2) GRU will, at all times, strive to supply service as constant and as reasonably practicable. However, GRU does not guarantee its electric service will be free from temporary interruptions. Temporary interruptions of service shall not constitute a breach of GRU's service obligations, and neither GRU nor the customer shall be liable to the other for damages resulting from temporary interruptions.
- 3) In the event of interruptions of service, service will be restored as soon as reasonably practical. In the event conditions on the customer's premises cause an interruption, GRU will allow a reasonable time for those conditions to be corrected, but may disconnect the service until the conditions are corrected to preserve the safety and reliability of the electric distribution system.
- 4) It is the customer's responsibility to install adequate protection for motors and other electrical equipment to prevent damages or losses due to service interruptions (total or partial, sustained or momentary), intolerable deviations in voltage (sustained or momentary), excessive current (load and fault currents), single phasing (loss of power in one or more phase conductors).

### **1.9 Connecting Safely (Electric)**

- 1) A permanent and effective grounding system furnished, installed and maintained by the is an essential part of any three wire single phase or four-wire three-phase wye connected service installation. This system must also be used for equipment grounding on any existing three phase, three wire (or four wire) delta connected service installations. GRU shall not be liable for any equipment damage or loss resulting from electrical discontinuity or diminished effectiveness of the distribution system neutral or service neutral conductor(s), should the customer's service entrance not be properly grounded.
- 2) The customer is responsible for retaining the services of a qualified consultant when designing service entrance equipment for available fault current. Customers should contact the Electric Engineering Dept.

### **1.10 Code Compliance and Inspection (Electric and Gas)**

- 1) GRU is prohibited from making the final connection between its electric distribution system and a customer's wiring system or gas distribution system and a customer's gas piping system until approval has been received from the inspection authority having jurisdiction (City or County inspectors) and has established a new customer account with GRU customer service.
- 2) No requirement contained in this document is intended to conflict with the National Electrical Code (NEC), the National Electrical Safety Code (NESC), the National Fuel Gas Code (NFGC) or any other applicable federal, state, county or municipal code or ordinance.
- 3) GRU has no obligation to determine whether or not the customer's wiring, equipment or general electrical installation or gas piping installation are proper and safe or comply with the above mentioned regulations, codes or ordinances. However, if a customer's electrical facilities are found to be unsafe, service may be refused or discontinued.
- 4) After the construction of GRU's installation is completed, a minimum of 3 business days is updates required to update GRU's GIS maps. The installation cannot be energized until the GIS map updates have been completed.

### **1.11 Access to Private Property (Easements and Clearances)**

- 1) GRU personnel must have access to the customer's premises at all time for the purpose of installing, reading, inspecting, repairing, removing, replacing, disconnecting, or otherwise maintaining its electric or gas meters, equipment, and facilities and for all similar purposes. If GRU is denied access to a premise, the meter location will need to be relocated at the customer's expense.
- 2) The customer shall grant or cause to be granted a minimum easement, or easements, as required by the type of electrical equipment installed, and private property access rights, as requested by GRU for the purpose of rendering safe and reliable service.
- 3) GRU easements and related access agreements must be prior to the installation of any GRU facilities. (See Definition for Easements on page 104).  
Note: Easements shall include the "Clearance" Requirements needed to install, remove or operate the equipment. See paragraph 1.11 4, below.
- 4) The customer must avoid any encroachment or interference with the construction and maintenance of GRU's facilities and any easement granted to GRU. To allow room for construction and maintenance the minimum horizontal clearances for pad mounted equipment is ten (10) feet in front of doors, four (4) feet on all other sides. The vertical clearance for pad mounted equipment, electric manholes and flush mounted electric boxes is clear to the sky or for pad mounted equipment installed in an Equipment "Nook", a space built into the side of a multiple story building, shall have a minimum vertical clearance of 28'-0". All Equipment "Nooks" must be pre-approved by GRU Electrical Engineering. The size of an Equipment "Nook" will vary according to the pad mounted equipment installed. All clearances shall be considered when designing the size of the Equipment "Nook". There shall be full access to all pad mounted equipment from the opening of the Equipment "Nook". For overhead and underground facility clearances see drawings on pages 14 through 21.

- 5) Easements and clearances shall remain free of debris to allow access to equipment by GRU personnel, not to be sodded over or landscaped around, free of dirt and maintained at or above ground level for the ease of locating. Gates shall have a minimum of a ten (10) foot opening for drivable access and the gate shall be maintained by the owner and remain unlocked for access. If a lock is required, a GRU system lock will be installed. Electric facilities must be accessible from the roadway or closer paved surface. This pertains to both overhead and underground facilities.

## **1.12 Typical Drawings**

All new services shall conform to the typical drawings in this guide, as applicable for the service type. A qualified GRU Employee must approve any exception in writing.

## **1.13 Vegetation Management** ← [click here to find more information regarding Tree Trimming](#)

- 1) Reasons for Vegetation Management
  - a) Protect electric infrastructure from damage
  - b) Prevent electrical outages caused by vegetation
  - c) Safety (Public and Employee)
- 2) Vegetation Management Programs
  - a) Cyclic Trimming
  - b) Danger/Hazard Tree Assessments
  - c) Herbicide Spraying
  - d) Mowing



## SINGLE FAMILY DETACHED RESIDENTIAL SERVICE CONVERSION FROM OVERHEAD TO UNDERGROUND

### NOTES:

- 1) GRU approved meter socket, conduit (from meter to Service Enclosure) and Service Enclosure are furnished and installed by customer. (Approved GRU materials found in Energy Delivery Service Guide Appendices).
- 2) All Riser conduit from transformer to Service Enclosure and all cable from overhead transformer to customer meter shall be paid for by customer and installed by GRU
- 3) All connections at the transformer and underground Service Enclosure will be made by GRU.
- 4) Ownership of any customer installed conduit system (except the Meter Riser Conduit) for a detached single family residential service will be transferred to GRU upon acceptance.
- 5) See Section 2, page 30, for the drawing showing the dimensional details for an Underground Residential Single Family Detached installation.
- 6) Conversion fee is based on the detailed construction estimate provided by GRU.

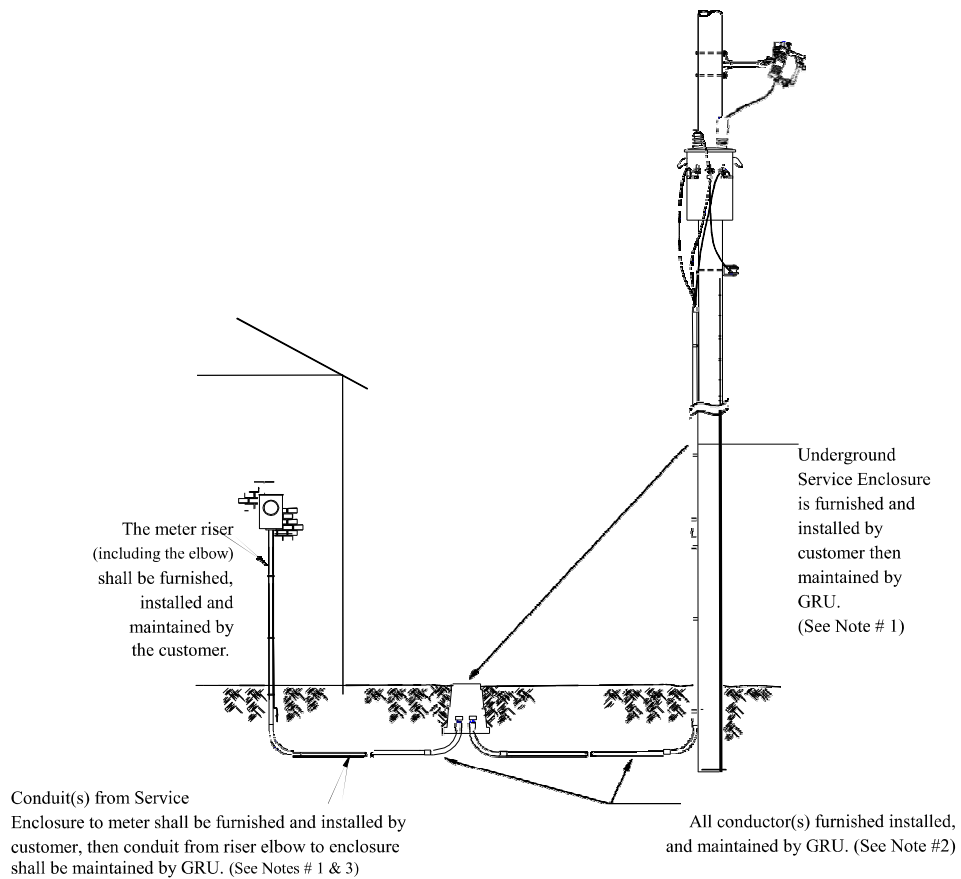

**TYPICAL PAD MOUNTED SINGLE PHASE TRANSFORMER  
EASEMENT/CLEARANCE DETAIL**

NOTES:

- 1) To allow for construction and maintenance a minimum of ten (10) feet of clearance in front of the door and four (4) feet of clearance on all other sides of pad mounted Single Phase Transformer is required. **Please do not place trees, shrubs or other obstructions in this area.**
- 2) Transformers shall be located a minimum of four (4) feet from the building drip line and ten (10) feet from any window or door.
- 3) A 12'-0" x 18'-0" Easement is required to install a GRU Pad Mounted Single Phase Transformer. This Easement includes the "Clearance" Requirement needed to install, remove or operate this equipment.
- 4) To allow room for construction and maintenance the customer shall grant GRU Delivery Division a **minimum** 15 foot utility easement centered on the underground utilities (7.5' on each side), for the purpose of rendering safe and reliable services (see page 1 this section).

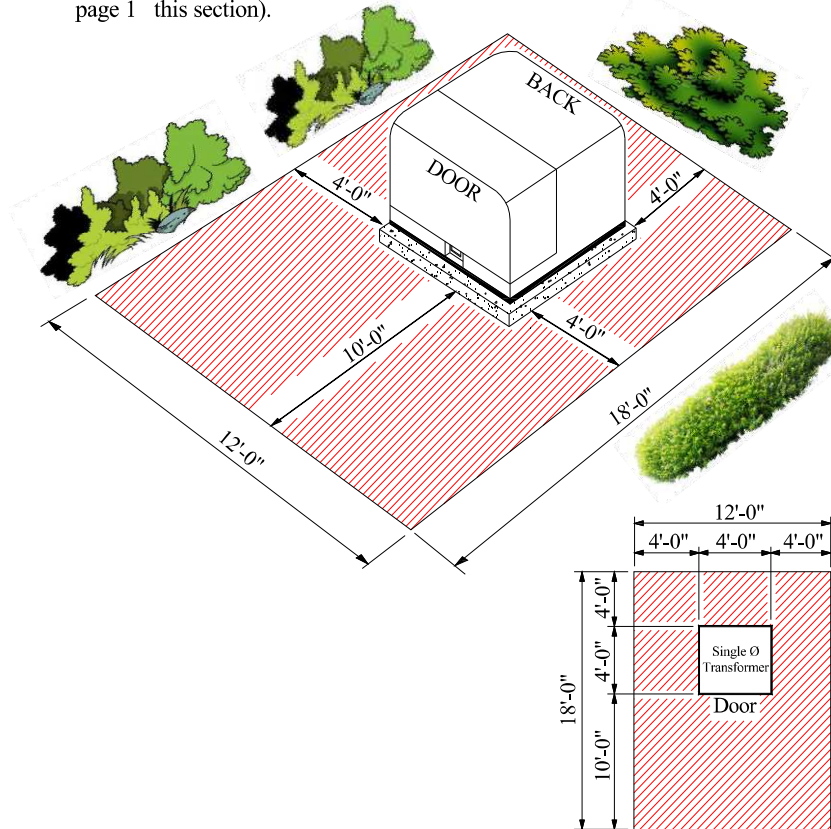

**TYPICAL THREE PHASE PAD MOUNTED TRANSFORMER  
EASEMENT/CLEARANCE DETAIL**

**NOTES:**

- 1) To allow for construction and maintenance a minimum of ten (10) feet of clearance in front of the doors and four (4) feet of clearance on all other sides of pad mounted three phase transformer is required. **Please do not place trees, shrubs or other obstructions in this area.**
- 2) Transformers shall be located a minimum of four (4) feet from the building drip line and ten (10) feet from any window or door.
- 3) A 16'-0" x 21'-0" Easement is required to install a Pad Mounted Three Phase Transformer. This Easement includes the "Clearance" Requirement needed to install, remove or operate this equipment.
- 4) To allow room for construction and maintenance the customer shall grant GRU Energy Delivery Division a **minimum** 15 foot utility easement centered on the underground utilities (7.5' on each side), for the purpose of rendering safe and reliable services (see page 1 this section).

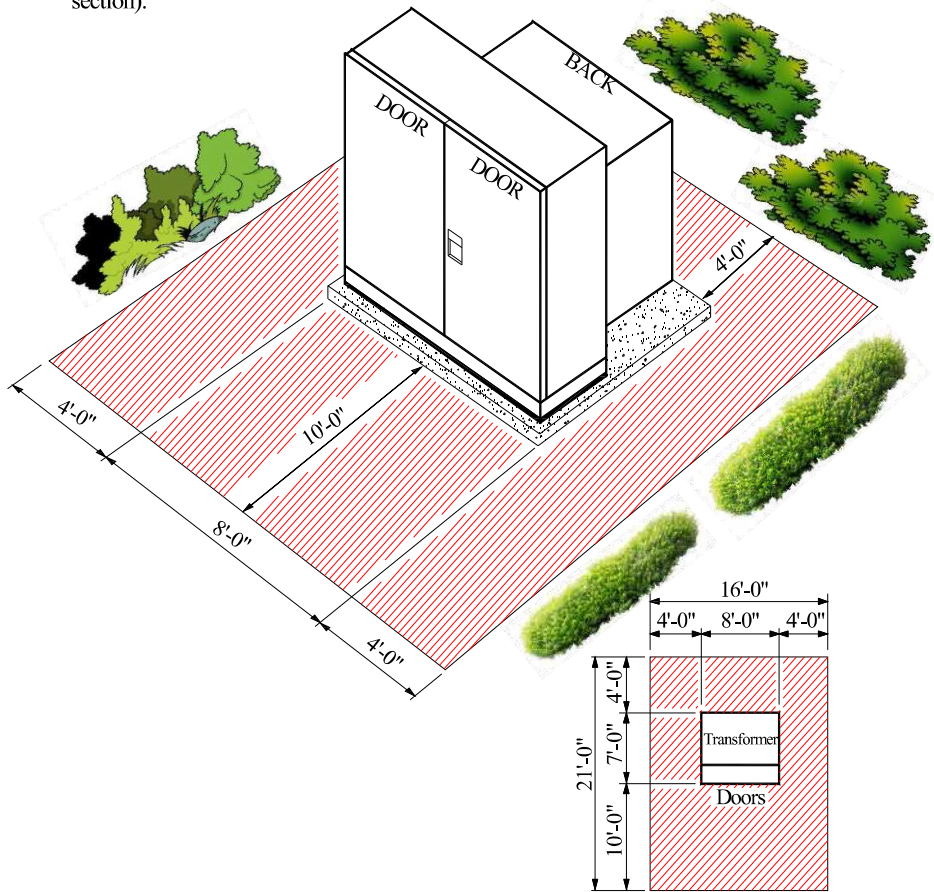

**TYPICAL PAD MOUNTED SWITCHGEAR EASEMENT/CLEARANCE DETAIL**

NOTES:

- 1) To allow for construction and maintenance a minimum of ten (10) feet of clearance in front of all doors and four (4) feet of clearance on all other sides of pad mounted switchgear is required. **Please do not place trees, shrubs or other obstructions in this area.**
- 2) Switchgear shall be located a minimum of four (4) feet from the building drip line and ten (10) feet from any window or door.
- 3) A 27'-0" x 15'-0" Easement is required to install a Pad Mounted Switchgear. This Easement includes the "Clearance" Requirement needed to install, remove or operate this equipment.
- 4) To allow room for construction and maintenance the customer shall grant GRU Energy Delivery Division a minimum 15 foot utility easement centered on the underground utilities (7.5' on each side), for the purpose of rendering safe and reliable services (see page 1 this section).

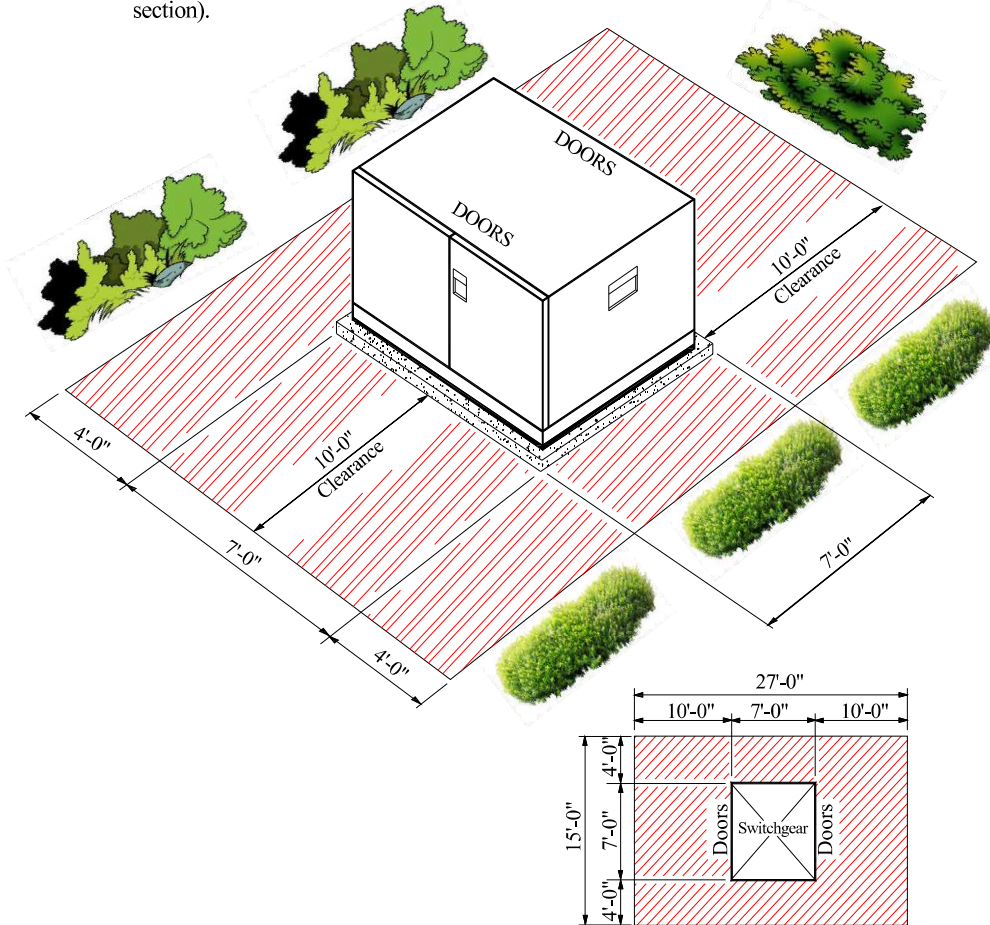

**TYPICAL UNDERGROUND UTILITY CONDUIT/CABLE  
EASEMENT/CLEARANCE DETAIL**

NOTES:

- 1) To allow room for construction and maintenance the customer shall grant GRU Energy Delivery Division a minimum 15 foot utility easement centered on the underground utilities (7.5' on each side), for the purpose of rendering safe and reliable service. Per the City of Gainesville Ordinance underground utilities shall be placed a minimum of 5'-0" from the root plate of an existing mature or a future mature tree.

**Please do not place trees, shrubs or other obstructions in this area.**

- 2) Please note, the Utility Easement includes the "Clearance" requirement from obstructions (trees) needed to install, remove or maintain underground power lines.

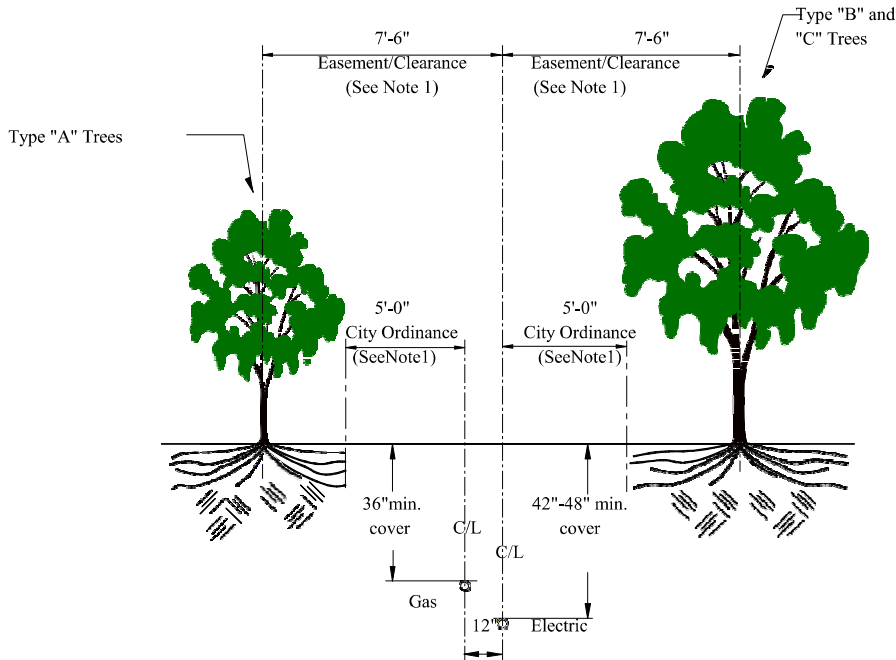

Type "A": Crown height and spread of 30 feet or less  
 Type "B": Crown height and spread of 30 to 60 feet  
 Type "C": Crown height and spread over 60 feet



## TYPICAL OVERHEAD UTILITY CLEARANCE DETAIL

### NOTES:

- 1) To allow room for construction and maintenance the customer shall grant GRU Energy Delivery Division a minimum 20 foot utility easement centered on the power pole, for the purpose of rendering safe and reliable service. Please do not place trees, shrubs or other obstructions in this area.
- 2) Please note, the Utility Easement may or may not include the "Clearance" Requirement from overhead obstructions (trees) needed to install, remove or maintain overhead power lines.
- 3) Per City of Gainesville Ordinance no shade tree that exceeds 40 feet in height at maturity shall be placed within 15 feet of any overhead utility.

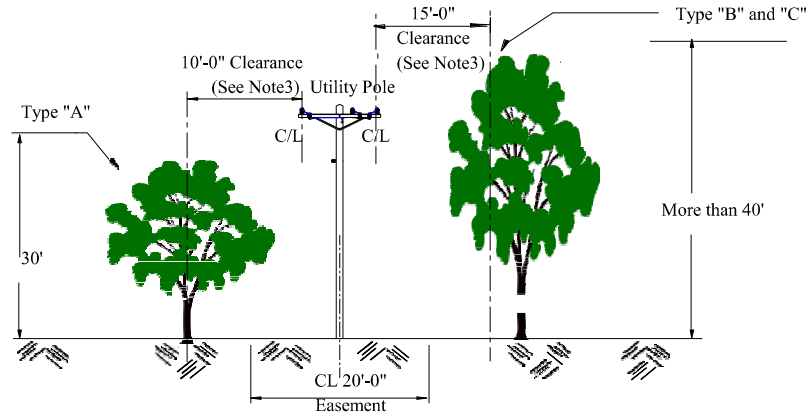

Type "A": Crown height and spread of 30 feet or less  
Type "B": Crown height and spread of 30 to 60 feet  
Type "C": Crown height and spread over 60 feet

**\* Gainesville Regional Utilities - Underground Electric and Water Facilities Separation Requirements**

Water Main	WW Force Main	WW Gravity Main	Reclaimed Water Main	Fire Hydrant	Water Meter	Storm Sewers	
3'	3'	10'	3'	3'	3'	3'	Electric UG

**\* Notes: 1)**

The NESC - National Electric Safety Code - states that, "conduit should be installed as far as is practical from a water main in order to protect it from being undermined if the main breaks. Conduit that crosses over a water main shall be designed to have suitable support on each side as required to limit the likelihood of transferring any direct loads onto the main.

**Gainesville Regional Utilities - Underground/Overhead Electric, Gas, GRUCom Facilities and Tree Separation Requirements**

Gas	GRUCom	Trees				
		Small	Medium	Large	Live Oak	
2'	1'	7'- 6"	7'- 6"	7'- 6"	7'- 6"	Electric UG*
NA	NA	10'	10'	10'	15'	Electric OH*
NA	NA	10'	10'	10'	10'	Electric UG Pad Mtd**
NA	NA	4'	4'	4'	4'	Lighting

**Notes:**

- \*1) These measurements above are from the center of the GRU Overhead conductor or Underground cable to the center of the Tree Trunk.
- \*\*2) This measurement is from the edge of the Pad of the Pad Mounted Equipment to the center of the Tree Trunk.

## VERTICAL PAD MOUNTED TRANSFORMER CLEARANCES FOR MULTIPLE STORY BUILDING DETAIL (TYP.)

**NOTES:**

- 1) Vertical clearances for pad mounted equipment shall be clear to the sky or for pad mounted equipment installed in an Equipment "Nook", a space built into the side of a multiple story building, shall have a minimum vertical clearance of 28'-0".
- 2) All Equipment "Nooks" must be pre-approved by GRU Electrical Engineering.
- 3) The size of the Equipment "Nook" will vary according to the type of pad mounted equipment installed.
- 4) Transformer shall be located a minimum of four (4) feet from the building drip line and ten (10) feet from any window or door. All clearances shall be considered when designing the size of the Equipment "Nook".
- 5) There shall be **full** access to the pad mounted equipment from the opening of the Equipment "Nook".

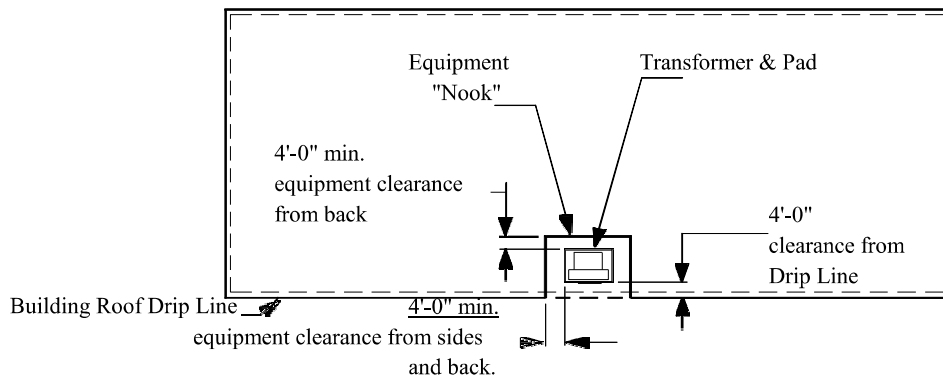
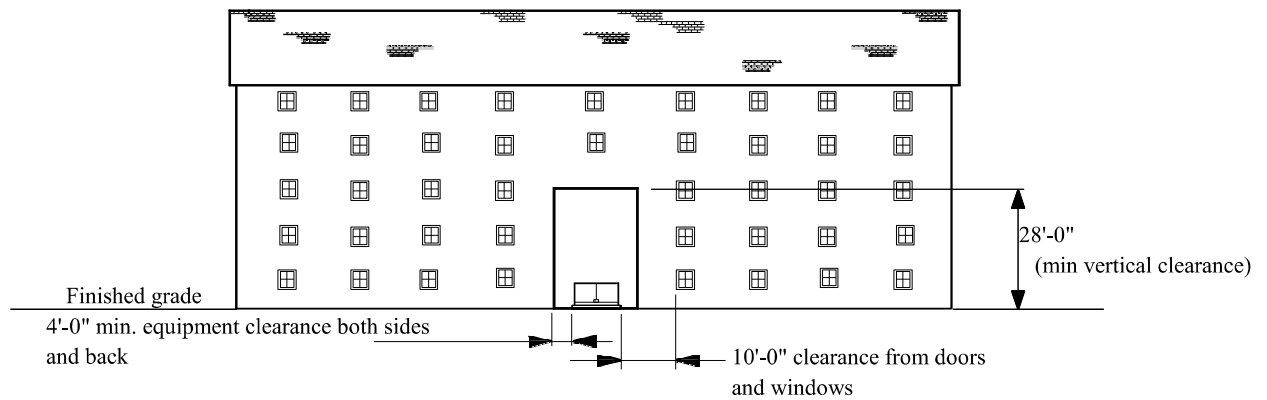

## VERTICAL PAD MOUNTED SWITCHGEAR CLEARANCES FOR MULTIPLE STORY BUILDING DETAIL (TYP.)

### NOTES:

- 1) Vertical clearances for pad mounted equipment shall be clear to the sky or for pad mounted equipment installed in an Equipment "Nook", a space built into the side of a multiple story building, shall have a minimum vertical clearance of 28'-0".
- 2) All Equipment "Nooks" must be pre-approved by GRU Electrical Engineering.
- 3) The size of the Equipment "Nook" will vary according to the type of pad mounted equipment installed.
- 4) Switchgear shall be located a minimum of four (4) feet from the building drip line and ten (10) feet from any window or door. All clearances shall be considered when designing the size of the Equipment "Nook".
- 5) There shall be **full** access to the pad mounted equipment from the opening of the Equipment "Nook".

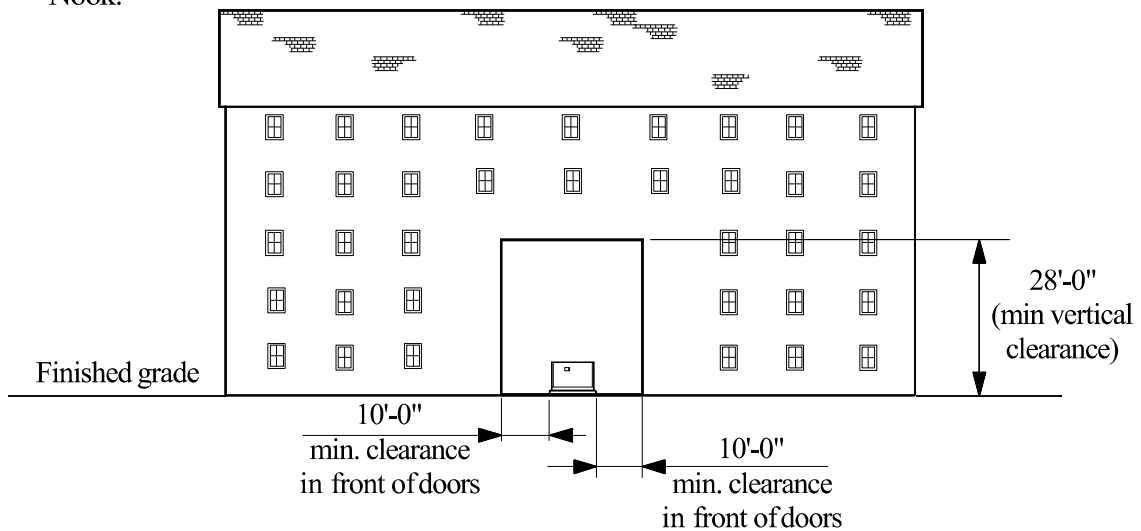

**Elevation View**

N.T.S.

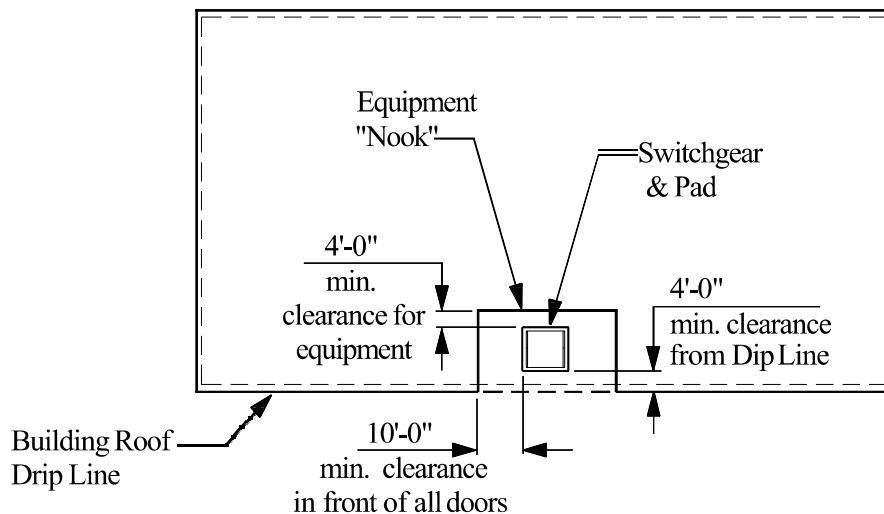

**Plan View**

N.T.S.

## VERTICAL PAD MOUNTED TRANSFORMER CLEARANCES FOR MULTIPLE STORY BUILDING DETAIL (TYP.)

NOTES:

- 1) Vertical clearances for pad mounted equipment shall be clear to the sky or for pad mounted equipment installed in an Equipment "Nook", a space built into the side of a multiple story building, shall have a minimum vertical clearance of 28'-0".
- 2) All Equipment "Nooks" must be pre-approved by GRU Electrical Engineering.
- 3) The size of the Equipment "Nook" will vary according to the type of pad mounted equipment installed.
- 4) Transformer shall be located a minimum of four (4) feet from the building drip line and ten (10) feet from any window or door. All clearances shall be considered when designing the size of the Equipment "Nook".
- 5) There shall be **full** access to the pad mounted equipment from the opening of the Equipment "Nook".

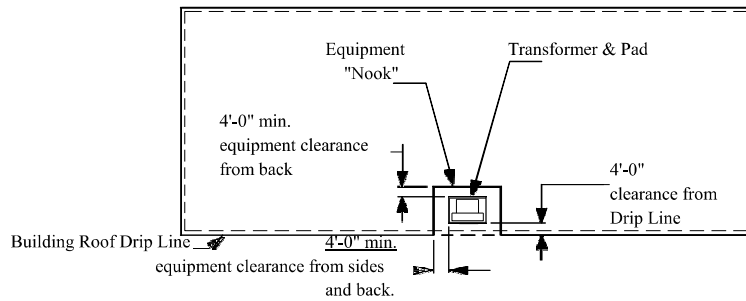
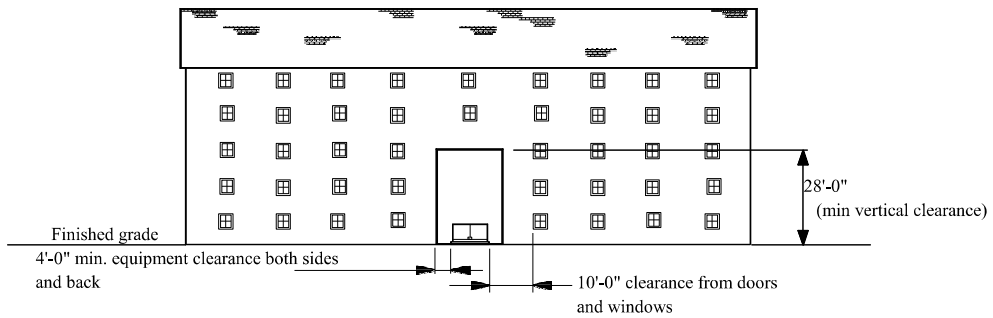



## Section 2: SERVICES AT SECONDARY VOLTAGES

### 2.1 General

- 1) To avoid unnecessary delays, customers should confirm the availability of service and obtain an approved meter location from a qualified employee before beginning construction. Meters are to be located closest to the GRU facilities from which service will be rendered. Meter installations that may later become inaccessible, (such as fenced rear or side yards) are to be avoided. Typically GRU service facilities are located in front of a building. (See Section 3 for Metering information).
- 2) Conductors carrying un-metered energy shall not be contained in the same raceway, trough, or conduit with conductors carrying metered energy.
- 3) All enclosures (e.g. disconnects, pullboxes, raceways, troughs, termination enclosures, etc.) with conductors carrying un-metered energy shall be fitted with an approved means for sealing or locking.
- 4) For safety reasons, the grounded conductor of the service conductors shall be plainly marked with white phase tape at the weatherhead and the meter socket unless the conductor is white, or gray.
- 5) This information was moved to Section 3; 3.39)
- 6) For service equipment rated larger than 400 amps (nominal rating) the service conductors shall be installed underground. Refer to the “City of Gainesville Code of Ordinances”. Refer to Section 4, for applicable installation requirements.
- 7) After the construction of GRU’s installation is completed, a minimum of 3 business days is required to update GRU’s GIS maps. The installation cannot be energized until the GIS map updates have been completed.

### 2.2 Secondary Service Voltages

- 1) Low voltage service will be provided to the customer from the nearest suitable source at one of the following nominal voltages:

<u>Phase</u>	<u>Wire</u>	<u>Nominal Voltage</u>
1	3	120/240 (residential)
1	3	120/208 (network)
3	4	120/208 (208Y/120)
3	4	277/480 (480Y/277)

- 2) All voltages are nominal and are subject to variations in accordance with Florida Public Service Commission rules (Chapter 25-6.046). Nominal frequency is sixty (60) hertz (cycles per second).
- 3) Single phase, 120/240 volt, 3 wire, grounded neutral service is normally available for residential, commercial and industrial use throughout GRU’s service territory.

- 4) Single phase, 120/208 volt, 3 wire, grounded neutral service may be the only single phase voltage available in some locations within GRU's service territory as a result of the limitations of existing facilities or by design. This voltage is typical in large apartment or condominium, complexes, commercial or industrial parks, and within the central city district.
- 5) Three phase, 120/208, and 277/480 volt, 4 wire, grounded wye services are available where three phase primary voltage distribution facilities exist. Service at these voltages will be rendered provided that the following demand criteria is met:
  - (a) Nominal voltage 120/208, 50kW demand.
  - (b) Nominal voltage 277/480, 150kW demand.
  - (c) An exception to this demand criteria will be made for multiple services supplied from the same transformer(s) when the total demand realized by all services meets the minimum demand criteria.
- 6) Prospective commercial customers that request three phase service but do not meet the minimum demand criteria may obtain this service if it is available in the immediate area, the customer agrees to pay for all costs to provide three phase service, and it is approved by GRU Energy Delivery Engineering.
- 7) Three-phase, 120/240 volt, 4 wire service is not available unless approved by the GRU Energy Delivery Engineering Manager or the designee on the basis of extreme hardship.
- 8) Three-phase service is not offered for new installations at a detached single family residence.

### **2.3 Overhead Secondary Service (Permanent)**

- 1) A qualified employee will designate the point of delivery between GRU's service drop and the customer's service entrance conductors after consultation with the customer. To comply with the appropriate safety codes, the point of delivery must provide clearances not less than those shown on pages 29 and 30.
- 2) All service masts/risers (installed from the meter socket to the Weatherhead) shall be no less than 2 inch trade size rigid galvanized steel conduit. A service mast/riser exceeding 3 feet in height above the roof shall be adequately guyed to withstand the strain imposed by the service drop. The service mast/riser shall be designed to support a minimum working load of 500 pounds. See drawing on page 29.
- 3) The customer shall furnish all hardware necessary for attaching GRU's service drop to a building. The customer is responsible for installing the hardware in a secure manner using a through-bolt attached to a structural member. The service attachment hardware shall be designed to support a minimum working load of 500 pounds.
- 4) Service entrance conduits shall be continuous from the weatherhead to the meter socket or disconnecting device, whichever is appropriate for the installation. Maintenance of the weatherhead and/or the mast extension is the responsibility of the customer.
- 5) Service entrance conductors shall comply with the National Electrical Code (NEC), as required by the inspection authority having jurisdiction. All service conductors located at the same point of service shall be made of the same conductive material (aluminum or copper). These conductors shall extend a minimum of three (3) feet beyond the weatherhead to allow connection.

- 6) The maximum span length of the service-drop conductors GRU will install is determined by the characteristics of the load to be served. If it is necessary to maintain minimum clearance, one (1) pole may be installed by GRU on the customer's property at no additional expense. Under no circumstances will the service-drop conductors attachment be made to trees.

#### **2.4 Underground Secondary Service (Permanent)**

- 1) The availability of underground service should be confirmed with GRU when the proposed project is in the design development stage. Residential meters shall be placed in the location closest to the GRU facilities from which service will be rendered. Meter installations that may later become inaccessible, (such as fenced rear or side yards) are to be avoided. (See Section 3 for Metering information). Customers desiring underground service in residential and commercial developments should also refer to Section 4.
- 2) The point of delivery between GRU's distribution system and the customer's facilities (or equipment) shall be determined by a qualified GRU employee after consultation with the customer. The customer or developer shall furnish and install all conduit (conduit shall be installed with one piece of continuous pre-lubricated woven polyester pull tape with printed sequential footage markings), concrete equipment foundations and related civil infrastructure. The customer or developer shall furnish only those approved materials listed in the Energy Delivery Guide Appendices. All customer installed conduit, concrete equipment foundations and related civil infrastructures and materials shall be inspected and approved by GRU. The customer must pass the GRU inspection before GRU can provide service. Service conductors shall be furnished as follows:
  - (a) GRU will furnish and install service conductors in the customer installed conduit from the GRU transformer or underground enclosure to the line side of the meter socket for a detached single family residential service. Ownership of any developer installed conduit system for a detached single family residential service (except the Meter Riser conduit and elbow) will be transferred to GRU upon acceptance.
    - 1] If a residential customer has a second meter installed for other purposes (not primary house meter) the customer will purchase, install and maintain the conduit and conductor to the second meter.
  - (b) The customer shall furnish, install and maintain service conductors and conduit for all multi-position multi-meter installations, commercial services, and all other services not meeting the definition of detached single family residence. (See Glossary for Definition) (See Table I - Conduit Sizes for Underground Secondary Cable - Page 65).
  - (c) All customer owned and maintained utilities, (electric, natural gas, water, wastewater, reclaimed water and telecommunications), location requirements are the responsibility of the customer and will not be located by GRU.
- 3) Padmounted transformers will be located a minimum of four (4) feet three (3) feet outside the building drip line and ten (10) feet from any window or door. All Pad mounted equipment must have a minimum vertical clearance of 28 feet.
- 4) The largest three phase, padmounted transformer offered for 120/208 volt service is 1000kVA. The largest three phase, padmounted transformer offered for 277/480 volt service is 2500 kVA. Where circumstances require more capacity than can be supplied by one transformer, the customer should contact the Engineering Division well in advance of the anticipated service date.

- 5) Metering equipment shall be located outside and accessible to qualified employees of GRU. Meter sockets and enclosures shall not be mounted in or on padmounted transformers. A qualified employee shall approve specialized metering equipment requirements. (See Metering Section 3)
- 6) Padmounted transformers are the preferred method of providing service for commercial customers, apartments and condominiums. Service conductors, service conduits, secondary terminal enclosures and accessories shall be furnished, installed and maintained by the customer and shall remain the property of the customer. The final connection of the customer supplied service entrance conductors will be made at the transformer or underground enclosure by GRU.

**NOTE:**

All customer owned and maintained utilities, (electric, natural gas, water, wastewater, reclaimed water and telecommunications), location requirements are the responsibility of the customer and will not be located by GRU.

- 7) The size and number of service conductors which can be connected to one padmounted transformer is limited as follows:
  - (a) Each secondary bushing of a three-phase padmounted transformer will accept up to eight (8) sets of service conductors, with no conductor larger than 750 kcmil.
  - (b) Each secondary bushing of a single-phase padmounted transformer will accept up to eight (8) sets of service conductors, with no conductor larger than 500 kcmil.
  - (c) Due to limited space, the customer shall coordinate the size and placement of conduit(s) in a padmounted transformer with the Engineering Division.
- 8) When a customer's service requires more than the standard 8 sets of aluminum or copper GRU Electric Engineering. GRU Electric Engineering must approve this alternative in the project design development stage. GRU has approved one termination enclosure (30 positions per bus) which may be used to accommodate up to 30 sets of conductors. A qualified GRU Electric Engineering employee will provide the customer with the specifications for the GRU approved termination enclosures. All materials, including the termination enclosure, conduits and conductors, shall be purchased and installed by the customer per GRU Standard Material Specifications. The size of the conductors installed between the transformer and the termination enclosure shall be determined by GRU Electric Engineering. The point of delivery (POD) between the customer and GRU will be at the customer owned and maintained termination enclosure. The final connection at the transformer shall be made by GRU. The conduit(s) and conductors between the transformer and termination enclosure (POD) shall be owned and maintained by GRU after acceptance by GRU. All enclosures with conductors carrying unmetered energy (see Section 2, 2.0, 3) shall be locked by GRU with a GRU approved locking system. Customers needing access to this equipment shall contact GRU T&D Work Order Center at 352-393-1551.

## **2.5 Temporary Secondary Service**

- 1) Temporary service is available for construction, fairs, exhibits, and other similar temporary purposes. The term of temporary service shall not exceed one (1) year. Temporary service equipment served overhead must be located in areas specified and approved by GRU, typically within eighty (80) feet of a pole. These facilities must be constructed to conform to the minimum clearances required by the NESC and these clearances must be maintained as long as temporary service is provided. Contact Electric Engineering Dept. to schedule an on-site meeting to determine point of interconnection.

- 2) If additional electric distribution facilities must be constructed to furnish temporary service, the charge for installing and removing the service will be the actual cost of rendering service. Advance payment may also be required for the estimated cost of installing and removing any materials or equipment not required to render permanent service.
- 3) Temporary service equipment shall be furnished, installed, and maintained by the customer. Temporary service installations must be inspected and approved by the appropriate electrical inspector prior to the rendering of service. See drawing on page 30 and 31. (All temporary service installations shall be metered).
- 4) This information moved to 2.4; 1)
- 5) Only temporary service equipment served underground must be located in areas approved by GRU, typically within four (4) feet three (3) feet of a transformer, UD Service Enclosure, UD Junction Box, or pole.
- 6) Interconnection from a temporary service to a permanent meter socket or to the customer's permanent breaker panel or other permanent electrical equipment is not permitted.

## TYPICAL OVERHEAD INSTALLATION

### NOTES:

- 1) Conductors shall extend 3 ft. (min.) beyond weatherhead in accordance with paragraph 2.2 (5).
- 2) Customer shall furnish and install attachment hardware in accordance with paragraph 2.2 (3).
- 3) Service drop minimum clearance (above finished grade):
  - 16' - above residential driveways
  - 18' - above public driveways, alleys and roads
- 4) Three phase sockets are furnished and installed by customer but must be approved by the GRU Gas and Electric Measurement Department (GEM) prior to purchase and installation of any metering equipment.
- 5) Coordination with Electric Engineering is required.
- 6) The service mast/riser, installed from the meter socket to the weatherhead, shall be a minimum of 2" rigid galvanized steel conduit.

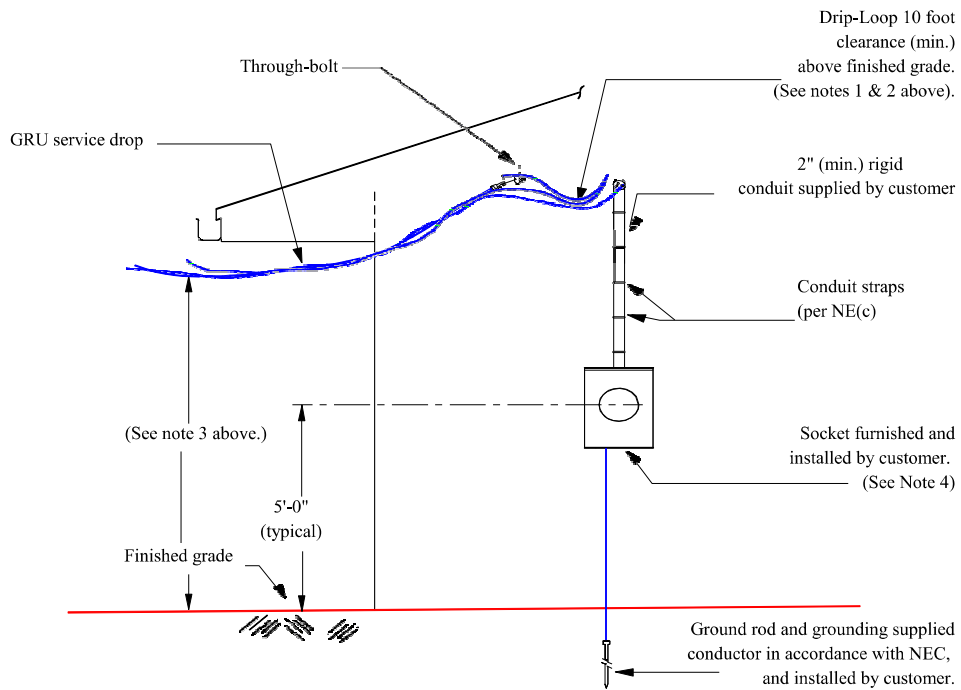

## TYPICAL SERVICE MAST INSTALLATION

### NOTES:

- 1) In accordance with Section 2, paragraph 2.2 (2) any service mast/riser exceeding 3 feet in height above the roof or last means of support shall be adequately guyed.
- 2) Conductors shall extend 3 feet (min.) beyond weatherhead in accordance with paragraph 2.2 (5).
- 3) Three phase sockets furnished and installed by customer.
- 4) Coordination with GRU Electric Engineering is required.
- 5) Maintain not less than 3'-0" vertical clearance above roof outside a 6'-0" radius from the service mast/riser (see drawing below).
- 6) Maintain not less than 18" vertical clearance (including the drip loop) above the roof within a 6'-0" radius from the service mast/riser (see drawing below).
- 7) The service mast/riser, installed from the meter socket to the weatherhead, shall be a minimum of 2" rigid galvanized steel conduit.

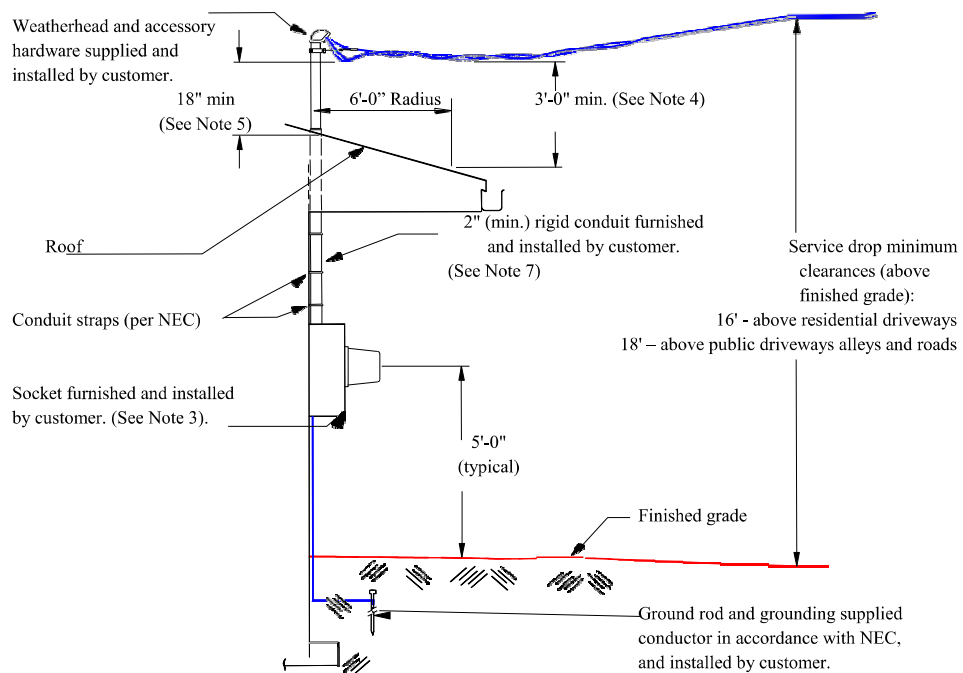



**TYPICAL RESIDENTIAL SINGLE FAMILY DETACHED UNDERGROUND INSTALLATION**

NOTES:

- 1) Customer shall locate loadside conduit on right side of socket, lineside conduit on the left.
- 2) Customer shall provide and install service conduit to service pedestal or transformer.  
The Conduit Riser and Elbow will remain the property and responsibility of the customer.
- 3) Coordination with Electric Engineering is required.

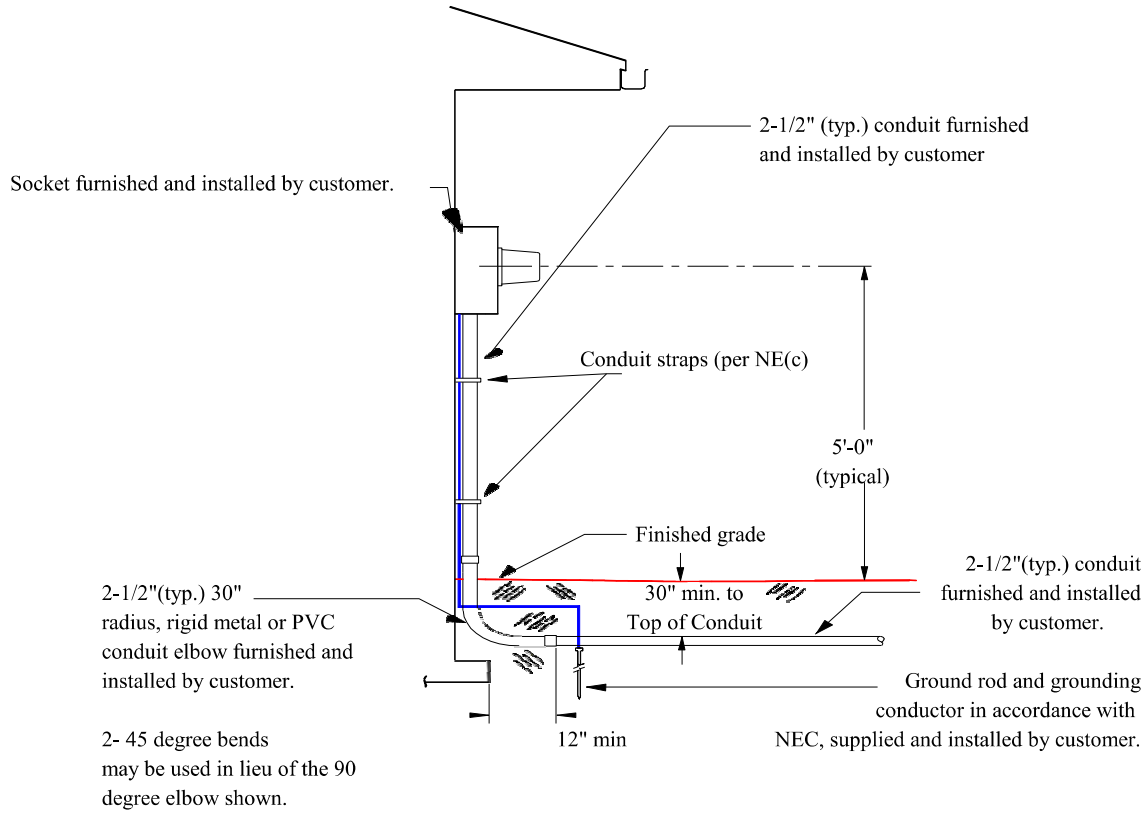

**TYPICAL OVERHEAD TEMPORARY SERVICE INSTALLATION**

NOTES:

- 1) Pole shall not be located in Right-of-Way.
- 2) Service drop minimum clearance (above finished grade):
  - 16' - above residential driveways,
  - 18' - above public driveways, alleys and roads
- 3) Coordination with Electric Engineering is required.

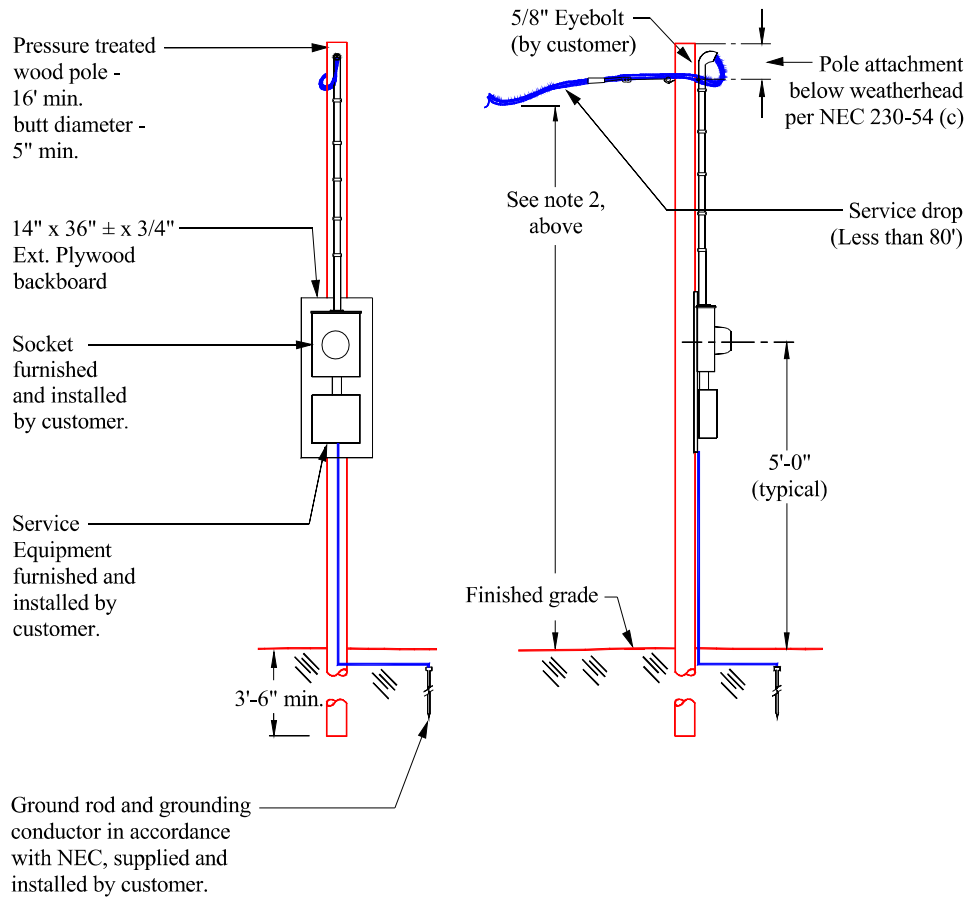

**TYPICAL UNDERGROUND TEMPORARY SERVICE INSTALLATION**

**NOTES:**

- 1) Pole shall not be located in Right-of-Way.
- 2) Mounting pole shall be pressure treated 4" x 4" x 8'-0" min.
- 3) Extend service conductors 3'-0" above finished grade.
- 4) Coordination with Electric Engineering is required.

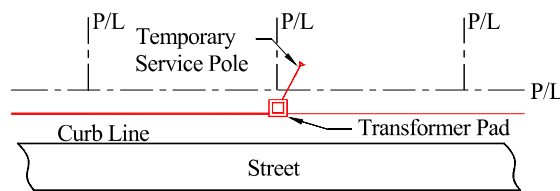
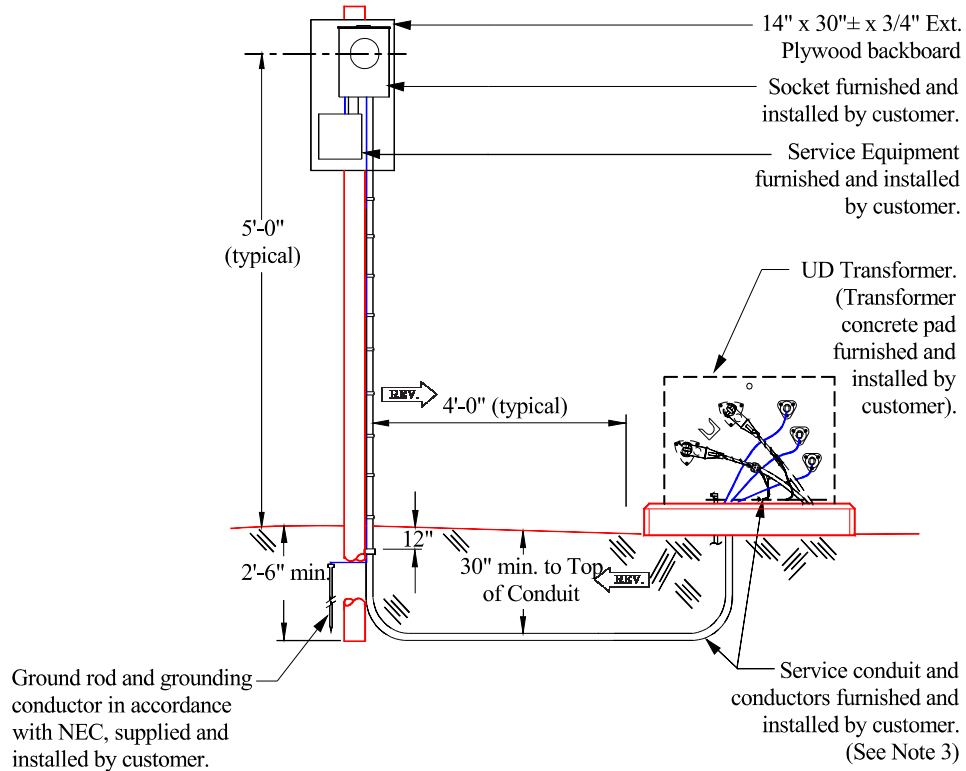

Plan view showing typical placement at temporary underground service.

## **Section 3: METERING AT SECONDARY VOLTAGES**

### **3.1 Approval of Metering Equipment Installation**

- 1) The GRU Gas and Electric Measurement (GEM) Department must approve all proposed metering installations prior to the installation of any metering equipment. Customers are encouraged to contact the GEM Department before purchasing or installing any metering equipment.
- 2) All meter enclosures shall comply with Appendix C, Customer Owned Meter Enclosure Specification and Section 3 of this guide.

### **3.2 Responsibility for Furnishing, Installing and Maintaining Metering Equipment**

- 1) The customer shall furnish and install all single-phase self-contained meter sockets. (See Appendix, C pages C-12 and C-13 for application requirements for 200 and 400 Amp. meter installations). The customer shall also furnish and install meter centers in accordance with paragraph 3.7 (2) and Appendix C. All customer furnished meter centers, including accordance those listed on the "Florida Meter Group's Approved Metering Enclosure List", shall be submitted for approval to GRU's Gas and Electric Measurement (GEM) Division prior to purchase or installation.
- 2) In addition to the sample approved meter sockets in Appendix C, the customer furnishes and installs the following equipment in accordance with the requirements of this section:
  - (a) Multiple position (gang type) meter sockets serving no more than five (5) customers (including house meter), when no individual customer's service is rated more than 200 amperes nominal and/ or the fault current is less than 10,000 amperes (see paragraph 3.7 (1)).
  - (b) Meter centers for residential and commercial services.
  - (c) Non-standard size instrument transformer enclosures shall be hinged and have pad lockable doors.
  - (d) Miscellaneous equipment including wiring troughs, overcurrent protective devices, disconnects, ground rods, conduit and all other materials required for installation.
- 3) The customer shall furnish and install the line side secondary cables and conduit for all services (except as noted in paragraph 2.3 (2) (b) ((c))
- 4) The customer shall furnish and install all three-phase self-contained and transformer rated meter sockets.
- 5) GRU furnishes but does not install the following equipment:
  - (a) Instrument transformers (CTs/PTs)
- 6) Metering equipment furnished by GRU to be installed by the customer will be supplied as complete units in good operating condition. This equipment is the property of GRU and shall only be used to meter GRU customers.
- 7) All revenue meters and instrument rated metering equipment shall be maintained by GRU. All self-contained meter enclosures and instrument transformer enclosures shall be maintained by the customer.

### 3.3 General Requirements for Installation of Metering Equipment

- 1) A qualified GRU GEM employee shall perform connections to all instrument transformer rated meter sockets, instrument transformers and other equipment affecting metering accuracy.
- 2) All non-current-carrying metal parts of meter sockets and instrument transformer cabinets shall be bonded to the grounded conductor (neutral) of the service. When grounding conductors pass through a meter socket enclosure and/or an instrument transformer enclosure, they must be bonded to the enclosure.
- 3) Meter sockets or metering cabinets containing utility owned revenue equipment shall not be used for the splicing, connecting, or routing of any conductors not directly related to the metering function. No additional circuits, junctions, or raceways are permitted to pass through or terminate within the meter socket enclosure.
- 4) All self-contained meter sockets for use in commercial applications shall be constructed with a manual lever bypass.
- 5) Where aluminum conductors are terminated in meter sockets or other equipment, oxide inhibitor of the non-grit type shall be applied to each conductor connector and around the circumference of each conductor at the connection point, including the grounded conductor (neutral).
- 6) Only one conductor is permitted in each connector of meter sockets, unless the socket is equipped with a parallel rated connector.
- 7) In order to use or install meters and meter sockets in accordance with their UL listing or label, (as required by the NEC), secondary voltage fault currents in excess of 10,000 amperes symmetrical require the installation of service disconnecting means and overcurrent protection at the meter socket(s) on the load side. Therefore, the customer must presume that the available short circuit current will be greater than 10,000 amperes unless specifically calculated otherwise by a qualified person. The customer is advised to select and/or specify all metering equipment accordingly (see reference Table III, page 35).

Note: Service provided from a 25 kVA transformer (or smaller) will result in less than 10,000 amperes of available fault current regardless of the service cable length, size, or conducting medium.

- 8) When a single transformer will serve more than one meter center, or when a meter center is installed in a multi-level building, each meter center per floor shall have its own line side disconnect with overcurrent device.
- 9) For proper metering of four wire, three phase, delta service the phase having the highest voltage to ground (high leg) must be in the right hand or "C" phase position in the meter socket. To insure proper connections, the phase having the highest voltage to ground (high leg) must be plainly marked with orange tape at the weatherhead and inside the meter socket.

### **3.4 Mounting Requirements for Metering Equipment**

- 1) Metering equipment shall be surface mounted in a location acceptable to a qualified employee.
- 2) To insure safety, accuracy, and reliability of service, it is necessary that meter sockets and metering cabinets be securely installed in a level and plumb position.
- 3) Meter sockets, metering cabinets and conduit straps should be installed with the following hardware:
  - (a) Masonry anchors when mounted on brick or solid concrete surfaces.
  - (b) Toggle bolts when mounted on masonry block.
  - (c) Wood screws when mounted on solid wood.
  - (d) Mounting fasteners not less than 1/4" made of galvanized or stainless steel.
- 4) A minimum of four (4) fasteners shall be used to install meter sockets, metering cabinets or any other equipment.

**TABLE III: TRANSFORMER FAULT - CURRENT available at secondary terminals based on unlimited source. Consult with GRU for specific job application.**

KVA	TYPE	PHASE	VOLTAGE	% Z	BASIS OF DESIGN SHORT CIRCUIT AMPERES (SCA)	
37.5	Pole/Pad	1	120/240	1.5	10,417	SCA
50	Pole/Pad	1	120/240	1.5	13,889	SCA
75	Pole/Pad/ Submersible	1	120/240	1.5	20,833	SCA
100	Pole/Pad/ Submersible	1	120/240	1.6	26,042	SCA
167	Pole/Pad	1	120/240	1.6	43,490	SCA
250	Pole	1	120/240	5.0	20,833	SCA
3 - 25	Pole	3	208Y/120	1.5	13,889	SCA
3 - 37.5	Pole	3	208Y/120	1.5	20,833	SCA
3 - 50	Pole	3	208Y/120	1.5	27,778	SCA
3 - 75	Pole	3	208Y/120	1.5	41,667	SCA
3 - 50	Pole	3	480Y/277	1.5	12,034	SCA
3 - 75	Pole	3	480Y/277	1.5	18,051	SCA
3 - 100	Pole	3	480Y/277	1.6	22,563	SCA
3 - 167	Pole	3	480Y/277	1.6	37,681	SCA
75	Pad	3	208Y/120	1.4	14,881	SCA
112.5	Pad	3	208Y/120	1.4	22,321	SCA
150	Pad	3	208Y/120	1.4	29,762	SCA
225	Pad	3	208Y/120	1.4	44,643	SCA
300	Pad	3	208Y/120	1.4	59,524	SCA
500	Pad	3	208Y/120	1.4	99,206	SCA
750	Pad	3	208Y/120	5.32	39,160	SCA
1000	Pad	3	208Y/120	5.32	52,214	SCA
150	Pad	3	480Y/277	1.4	12,893	SCA
225	Pad	3	480Y/277	1.4	19,340	SCA
300	Pad	3	480Y/277	1.4	25,786	SCA
500	Pad	3	480Y/277	1.4	42,977	SCA
750	Pad	3	480Y/277	5.32	16,965	SCA
1000	Pad	3	480Y/277	5.32	22,620	SCA
1500	Pad	3	480Y/277	5.32	33,930	SCA
2000	Pad	3	480Y/277	5.32	45,239	SCA
2500	Pad	3	480Y/277	5.32	56,549	SCA

- 5) Hardcoat stucco structures that use fiberboard for backboard instead of concrete block must be reinforced with solid wood blocking behind backerboard and hardware shall be mounted with wood screws into the wood support.
- 6) Where the exterior wall is other than brick or concrete blocks, a frame (i.e. solid wood blocking) shall be installed behind the exterior wall to provide a solid mounting surface for metering equipment.
- 7) All meter positions shall be properly covered before unit is energized

### 3.5 Locating Metering Equipment

- 1) The preferred location for metering equipment is outdoors in fully accessible areas which shall be kept free of obstructions and open to Gas and Electric Measurements Dept. (GEM) personnel. When GRU service facilities are located in front of a building, the meter location should be placed on the side of the building closest to the service connection point in the front one-half of the side wall as designated by a qualified GRU GEM employee. For indoor installations, special permission must be obtained from a qualified GRU GEM employee.
- 2) Metering equipment shall not be located in sheds, attics, bedrooms, bathrooms, toilet rooms, kitchens, stairways, carports, patios, porches, furnace rooms, basements, GRU Poles\*, or in any location where there is less than 6 feet 6 inches of headroom. Metering equipment shall be located where it is readily accessible to GRU employees

**\*Exception:** *When a meter is serving a commercial Small Cell Communications antennal/control cabinet combination that is mounted on a single GRU pole, the meter shall be mounted inside a separate GRU Approved cabinet/socket on the same GRU pole as the commercial Small Cell Communications antennal/control cabinet combination. The meter cabinet/socket shall be constructed with a manual lever bypass and a main disconnect labeled as such. The meter cabinet/socket shall be mounted so that the center of the meter is 5 feet above final grade. This cabinet / socket shall be lockable with a GRU meter seal. Please reference Section 3.6 "Customer Furnished Meter Sockets" in this Energy Delivery Service Delivery Appendices, Appendix C: "Customer Owned Meter Enclosures for Self-Contained Watt hour Guide" and the "Energy Meter Specifications."*

- 3) The typical mounting height at the center of meter sockets and other metering equipment is 5 feet above final grade. The minimum allowable height at the center of the meter position shall be 2 feet-6 inches and the maximum allowable height at the center of the meter position shall be 5 feet -6 inches above final grade level. A qualified employee must approve deviations from the typical 5 feet-6 mounting height. These measurements also apply with regard to distance from the floor where special permission is obtained to locate the metering equipment indoors. A qualified employee in consultation with the customer will determine metering equipment mounting heights and locations.
- 4) Safety dictates that metering equipment shall be located so that GRU personnel are provided level, unobstructed working space. This working space should extend a minimum distance of 3 feet in front and 18 inches to either side of the equipment, and a height of 6 feet, 6 inches from final grade level (refer to the National Electrical Code for additional working space requirements).
- 5) Where no protective barriers are in place the customer shall provide clearance of at least 6 feet from machinery or other devices with moving parts.
- 6) Where special permission is obtained to locate metering equipment indoors, accessibility to GRU metering personnel and adequate lighting shall be provided to allow safe installation, maintenance and testing.



- 7) Metering equipment shall not be installed in a cabinet with gas meter(s). Gas regulator vents must maintain 36" clearance from sources of ignition. Please refer question regarding meter sets to the GRU Gas and Electric Measurement Department.
- 8) If it is necessary to locate metering equipment adjacent to a driveway, walkway, parking lot or any a qualified employee. In locations where metering equipment is subject to damage, a qualified employee may require the customer to furnish and install protective barriers.
- 9) Any location that affects metering accuracy will not be allowed.
- 10) No individual meter sockets shall be installed one above the other.
- 11) Typical metering installations are illustrated by the drawings at the end of this section. Any questions should be directed to a qualified employee.

### **3.6 Customer Furnished Meter Sockets**

- 1) When a customer furnishes the meter socket(s), the customer shall notify GRU well in advance of required service date and shall comply with the following information and Appendix C (Customer Owned Meter Enclosure Specification):
  - (a) The customer shall obtain approval for customer purchased metering equipment that is not in compliance with Appendix C. The label, symbol or other identifying mark used by the testing laboratory shall be affixed to the unit.
  - (b) Each meter socket shall be rated not less than the rating of the service equipment when used on single family dwellings. Each meter socket position shall be rated not less than the current capacity (in amperes) of the service or feeder conductors connected to the load side of the socket where multi- position metering assemblies are used.
  - (c) All meter spade jaws shall be spring reinforced.
  - (d) Ring type sockets must be equipped with screw-type sealing rings approved by the Meter Division and shall be used only with meter centers.
  - (e) Connectors for more than one conductor and connectors used to connect aluminum conductors must be approved for the purpose. Oxide inhibitor of the non-grit type must be used on all aluminum conductors. GRU will not accept more than one conductor under one pressure device unless it is specifically designed for that purpose.
  - (f) Conductors carrying un-metered energy shall not be contained in the same compartment, conduit, or raceway with conductors carrying metered energy.
  - (g) Meter sockets installed outdoors must be weatherproof (NEMA Type 3R).

### **3.7 Customer Furnished Multiple Position Metering**

- 1) The customer may furnish and install one (1) multiple position meter socket per building. The socket will have no more than five (5) positions (including position for a house meter), each rated 200 amperes (nominal), or less. In addition, the fault current at the meter socket shall not exceed 10,000 amperes in accordance with the requirements of paragraph 3.3 (7).

- 2) Customer furnished \* meter centers (Meter/Breaker combination units or enclosures) are required for all multi-unit buildings that do not qualify for a multiple position meter socket. All customer furnished meter centers, including those listed on the "Florida Meter Group's Approved Metering Enclosure List", shall be submitted for approval to GRU's Gas and Electric Measurement (GEM) Division prior to purchase or installation and shall be installed in accordance with the following requirements and Appendix C:
  - (a) The customer shall furnish and install all conduit and service conductors.
  - (b) Meter centers may be required to have line and/or load side disconnecting means with overcurrent protection, (see paragraph 3.3 (67) and (78), page 35 for specific requirements).
  - (c) Meter centers equipped with ring type meter sealing rings shall be good quality screw type rings approved by the GEM Division.
  - (d) Multiple Position Meter enclosures shall be furnished and installed in accordance with the typical drawings shown on pages 53, 54 and 57.
 

\*(Please Note: "Cutler Hammer/Eaton's 1MM and 3MM Meter Centers" and "General Electric TMM and TMP Meter Centers" shall not be used in Gainesville Regional Utilities (GRU) Service Area. However, the General Electric TMP "Meter Equipment Group Approved" (MEG) meter center and the "Cutler Hammer Eaton's" 1MM and 3MM Meter Equipment Group Approved" with the cotter pin assemblies are allowed. The "General Electric" "MEG Approved" meter center catalog number ends with the suffix letter "F" and the "Cutler Hammer/Eaton's 1MM and 3MM Meter Centers" catalog number ends with the suffix letter "P").
  - (e) Any meter center for commercial use shall come equipped with lever bypass handles. **"Horn bypass assemblies are not allowed for any application"**.
- 3) On multi-unit buildings where meter centers are utilized, the meter centers shall be arranged into one assembly with one (1) point of service (see also paragraph 1.4 (2)).
- 4) Multi-position, customer owned meter sockets (other than meter centers) shall be constructed so the line side wiring compartment is separate from compartments housing service equipment or meter sockets and is accessible without having to remove any meter(s). Each meter position's cover shall be removable without having to remove any other cover(s).
- 5) On multi-unit buildings where a wiring trough is utilized to serve more than one customer, a line side overcurrent device is required unless the service is fed from a dedicated transformer. A loadside disconnecting means is also required for each tenant. The disconnecting means shall be readily accessible to GRU personnel and shall accept a GRU lock. The disconnecting means is to enable GRU to disconnect and reconnect service to these customers without interruption of service to other customers served from the same trough. (See drawing on page 57.)
- 6) Where a single transformer serves more than one building, each meter shall have a socket lockable off load side disconnecting means with overcurrent protection located adjacent to the meter socket and accessible to GRU service personnel.
- 7) To minimize cross-metering and avoid delays in providing service to multi-unit facilities (i.e., apartments, condominiums, commercial facilities, etc.), the buildings, entrance to individual units, and meter sockets served shall be labeled as follows:

(a) Buildings and entrances to individual units

- 1- The building (address) identification shall be firmly affixed to the front of the building or to a separate structure in front of the building (such as a mailbox, post, wall, fence, etc.). The identification markings shall be displayed in a manner such that they are clearly visible and legible from the public or private roadway on which the building fronts.
- 2- The individual unit (i.e., apartment number) identification shall be firmly affixed to the adjacent wall next to the door jamb or centered on the entrance door of the unit or centered immediately above the door frame if room permits. The identification markings on the door shall be displayed at a minimum height of sixty-six inches (66") and a maximum height of at least two inches (2") below the top of the door.
- 3- Identification on apartment buildings shall be a minimum of three inches (3") high and one-half (1/2") inch wide and identification on the individual units shall be a minimum of two inches (2") high and one-quarter inch (1/4") wide.
- 4- The identification shall be of a contrasting color with the immediate background of the building or structure on which such markings are affixed.
- 5- The approved materials are wood, metal, or plastic.

(b) Meter socket enclosures and covers

- 1- Each meter socket enclosure and cover shall be permanently identified with the corresponding building and individual unit number which that meter serves.
- 2- Identification inside the meter socket enclosures and outside the meter socket covers shall be marked with no less than one-quarter inch (1/4") high lettering.
- 3- The approved method/materials are stamped lettering. Wood, metal, or plastic labels firmly attached by means of rivets are also allowed. Attachment by screws or glue is not allowed.
- 4- Refer to illustrations on pages 52 through 54, 56 & 57 for identification locations.

(c) Facilities not in compliance with the above guidelines during meter socket and wiring inspection will result in an automatic inspection failure, delays in meter installations, and may be assessed additional charges for multiple site visits.

### **3.8 Self-Contained and Instrument Transformer Metering**

- 1) Where the nominal rating of the service is greater than 200 amperes, but not more than 400 amperes, a self-contained meter socket will be furnished and installed by the customer. GRU may require instrument transformer metering if: The customer's actual demand results in a service with a continuous current that is greater than 400 amperes; or if in GRU's opinion an instrument transformer is required to assure metering accuracy or electrical service to Fire Pumps must have or must be served through an instrument rated Metered Service.
- 2) If required, instrument transformers will be furnished by GRU for customer installation or, at the option of GRU, installed by a qualified employee.
- 3) If required, an instrument transformer compartment shall be furnished by the customer for GRU metering equipment. (See paragraph 3.2 (5) (a)).

- 4) The customer shall furnish and install a one-inch (1") trade size rigid metal conduit (with a bitumastic coating where contacting earth) or 1" schedule 40 PVC conduit from the instrument transformers conduit into the meter socket test switch section. Conduit risers located subject to physical damage as determined by a qualified employee shall be rigid steel. See drawings on pages 50, 54, 55 and 56.
- 5) The maximum allowable distance from the meter socket to the instrument transformers is 25 feet. A maximum of three (3) 90 degree bends or equivalent is allowed in each run of conduit. All conduit ends shall be reamed to protect the meter control cable. All conduit ends shall be equipped with a bonding bushing when using rigid metal conduit.
- 6) When parallel service entrance conductors pass through current transformers, it is the customer's responsibility to have the same phase only through each transformer.
- 7) Due to special considerations and requirements for metering where instrument transformers are located in the customer's switchgear, each installation must be coordinated with the GEMS Department.
- 8) Where instrument transformers are to be located in the customer's switchgear, they shall be installed by the switchgear manufacturer at the customer's expense. Customer supplied instrument transformers shall have specifications and test results approved by the GEM Division prior to installation. The following requirements apply to instrument transformers in switchgear:
  - (a) Instrument transformers shall be installed AHEAD OF ALL LOAD for each tenant and in a separate compartment of the switchgear for each service.
  - (b) Each compartment shall be equipped with a hinged, padlock lockable door and shall be located such that metering personnel will have clear and unobstructed access to the instrument transformers.
  - (c) Manufacturer's installation instructions and a one-line diagram showing the location of the instrument transformers within the switchgear shall be sent to the GEMS Dept. prior to installation.
- 9) Where service is 277/480 volts the installation shall conform to the following additional requirements:
  - (a) Self-contained metering services shall have a disconnecting means on the line side of, and immediately adjacent to, the meter socket. Unless required by Code, this does not need to have overcurrent protection.
  - (b) The disconnecting means shall be rated not less than the load to be carried and must have an interrupting rating at system voltage sufficient for the current to be interrupted.
  - (c) The disconnecting means shall be readily accessible to GRU personnel and shall accept a GRU padlock.
- 10) Customers receiving services with a nominal rating of more than 400 amperes metered with instrument transformers shall furnish and install one telephone conduit for remote metering. One conduit is also required for each meter center or multiple position meter socket. Telephone conduit shall:
  - (a) Be provided with a pull line from the meter location to the telephone panel backboard in accordance with the directions of a qualified employee.
  - (b) Be 3/4" trade size rigid steel or PVC conduit. Conduit risers located subject to physical damage as determined by a qualified employee shall be rigid steel.
  - (c) Rigid metal conduit shall have a bitumastic coating applied when direct buried.

### **3.9 Metering Installations in Mobile Home Parks**

- 1) The mobile home feeder assembly shall terminate at the service equipment located adjacent to the mobile home and shall not terminate in the meter socket.
- 2) Overhead Installations
  - (a) The metering pole must be of sufficient height to provide service drop clearances as required for a typical installation. See drawing on page 58 and 59.
  - (b) All meter sockets shall be mounted in a manner that allows meters to be inserted and withdrawn without causing movement of the entire unit.
  - (c) The grounded conductor (neutral) and grounding conductor shall be bonded together at the service equipment in accordance with the National Electrical Code.
- 3) Underground Installations
  - (a) Mobile homes served by underground distribution must furnish meter pedestals for the connection of service laterals and watt-hour meters. Refer to Section 2.3 (2) (b) for underground service requirements. See drawing on page 60.
  - (b) Meter pedestals shall comply with Appendix C (Customer Owned Meter Enclosures) as specified in paragraph 3.6. GRU does not assume ownership of meter pedestals and is not responsible for maintenance.
  - (c) Grounding should be in compliance with the National Electric Code and applicable state or local codes.
  - (d) The enclosure must be designed to guard against unauthorized entry of stand-alone meter pedestals.

### **3.95 Metering Equipment Mounted on Manufactured Homes**

- 1) The NEC and HUD now both permit the service equipment and the meter socket to be mounted on a manufactured home under certain conditions.
- 2) GRU will serve manufactured homes with the service equipment and meter socket mounted on the home, provided the electrical inspector approves the installation. The following conditions must be met in order to serve a manufactured home with the service equipment and meter socket mounted on the home:
  - (a) Applicable code requirements must be met.
  - (b) Meter socket(s) supplied by the customer must comply with paragraph 3.6 of this document.
  - (c) The foundation to which the home is attached must be constructed in such a manner that it is obvious that the home is not intended to be moved.

**TYPICAL WIRING OF METER SOCKET FOR SINGLE PHASE TWO WIRE SERVICE**

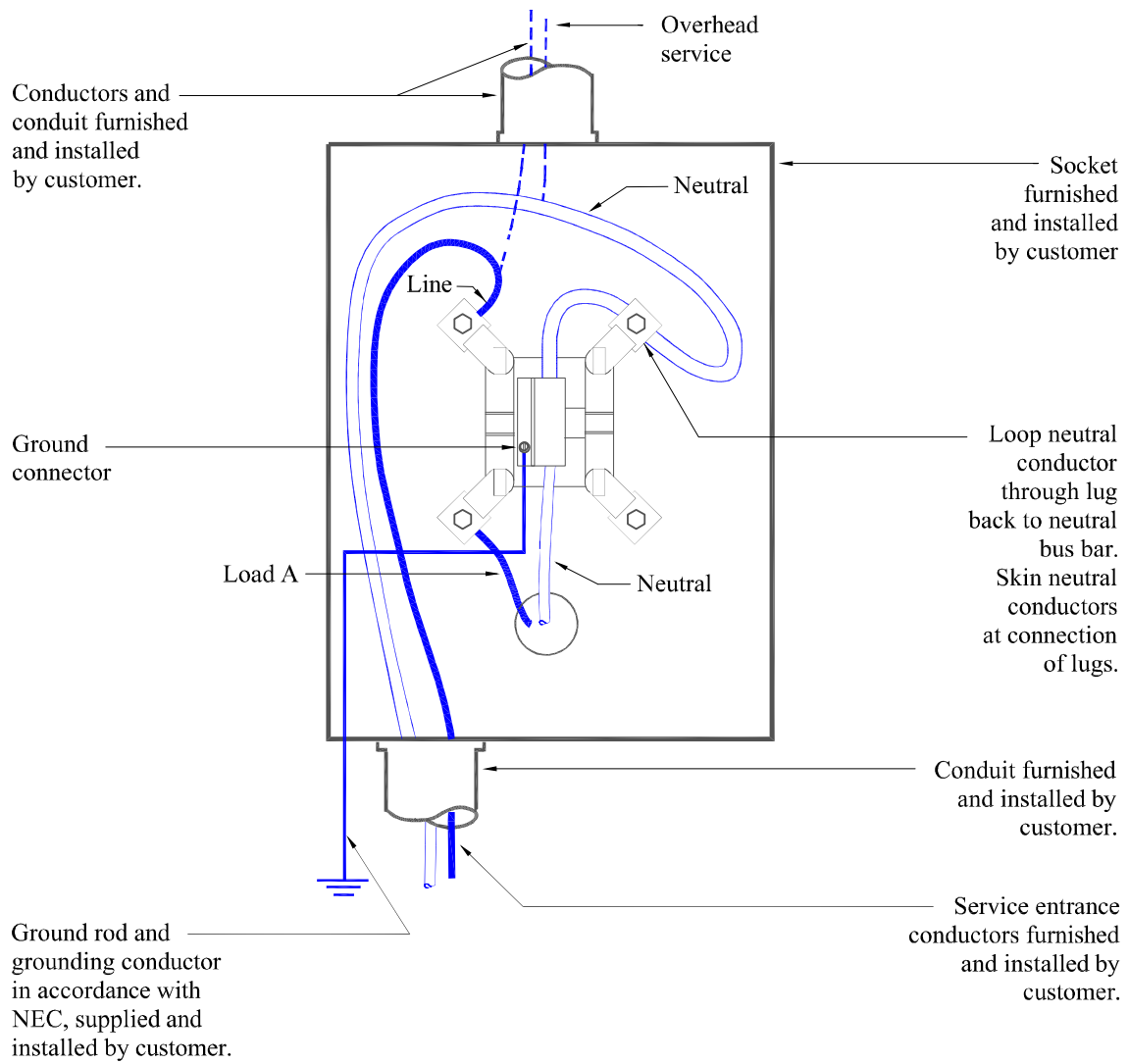

Specialized Application Only

**TYPICAL WIRING OF METER SOCKET FOR SINGLE PHASE THREE WIRE SERVICE (120/240)**

**NOTES:**

- 1) GRU will furnish and install service conductors for detached single family residential customers only.
- 2) Bypass capabilities required for single phase commercial applications.

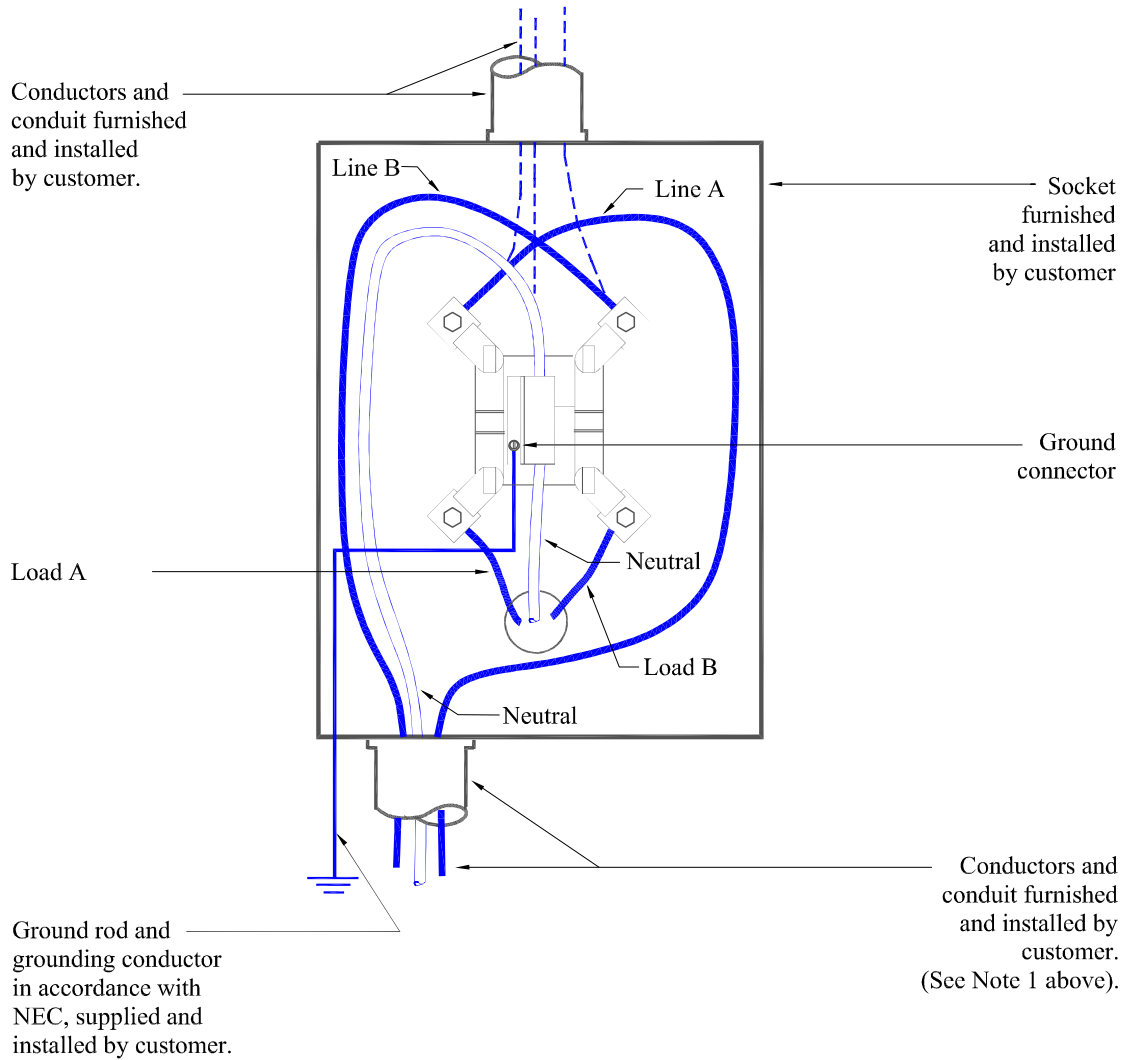

**TYPICAL WIRING OF METER SOCKET FOR TWO PHASE NETWORK THREE WIRE SERVICE (120/208)**

**NOTES:**

- 1) GRU will furnish and install service conductors for detached single family residential customers only.
- 2) Bypass capabilities required for single phase commercial applications.

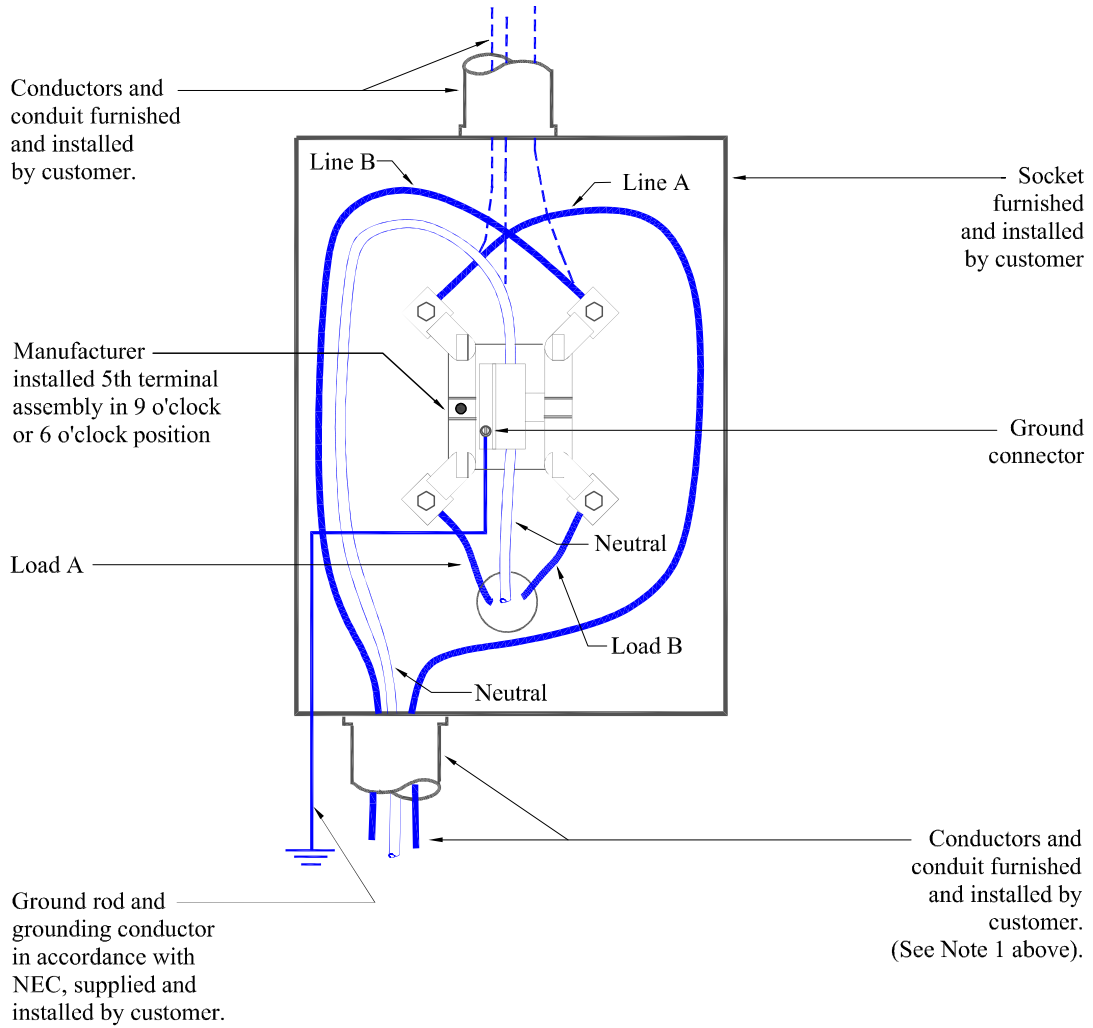



**TYPICAL WIRING OF METER SOCKET FOR THREE PHASE  
THREE WIRE SERVICE**

**NOTE:**

- 1) Services having a voltage rating of 277/480V shall have a line disconnect (ahead of the meter) furnished and installed by the customer and approved by a qualified employee.

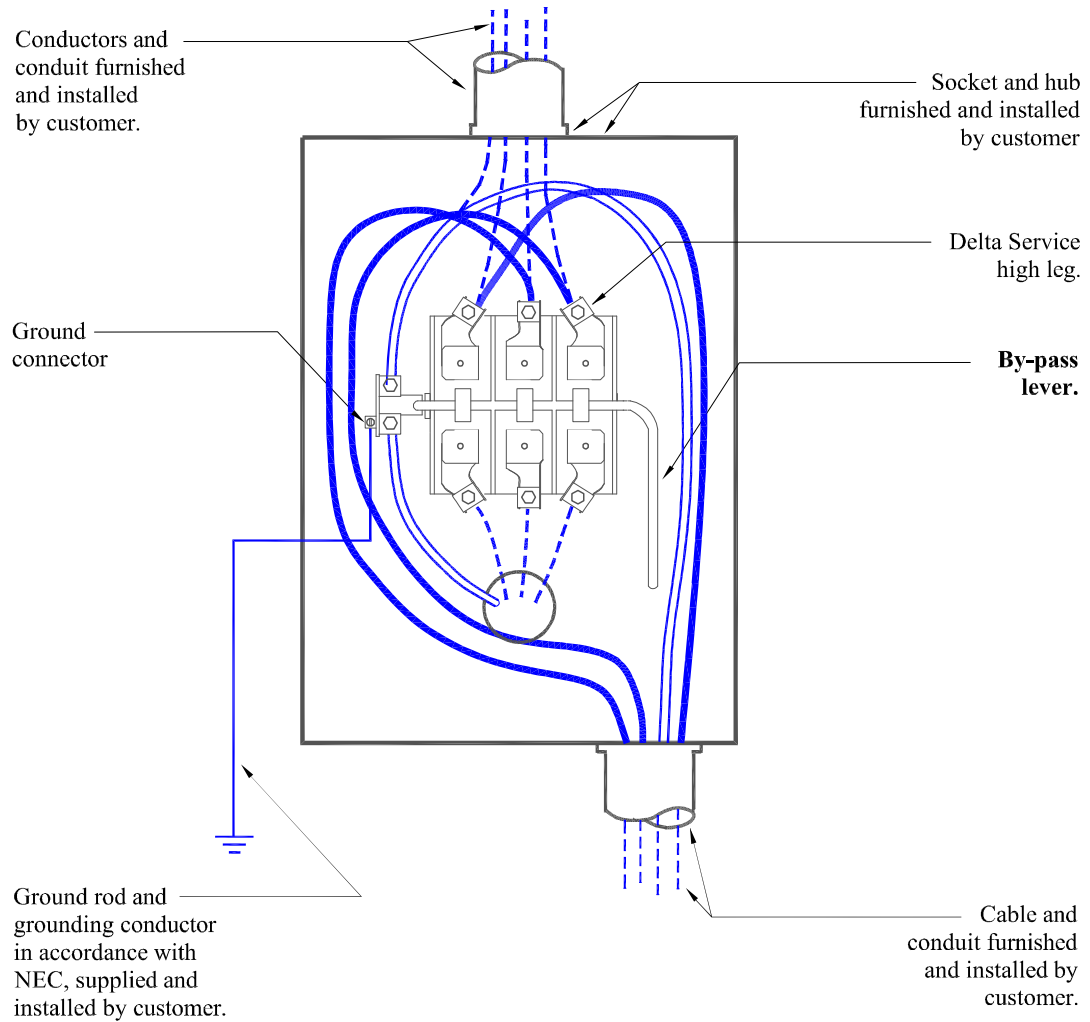

**TYPICAL WIRING OF UNDERGROUND SINGLE PHASE 480 AMP.,  
SELF CONTAINED, METER SOCKET**

**NOTES:**

- 1) Self contained meters are applicable where the service entrance conductor capacity is greater than 200 amperes, but not more than 480 amperes continuous. See paragraph 3.8.
- 2) GRU will furnish and install service conductors for detached single family residential customers only.

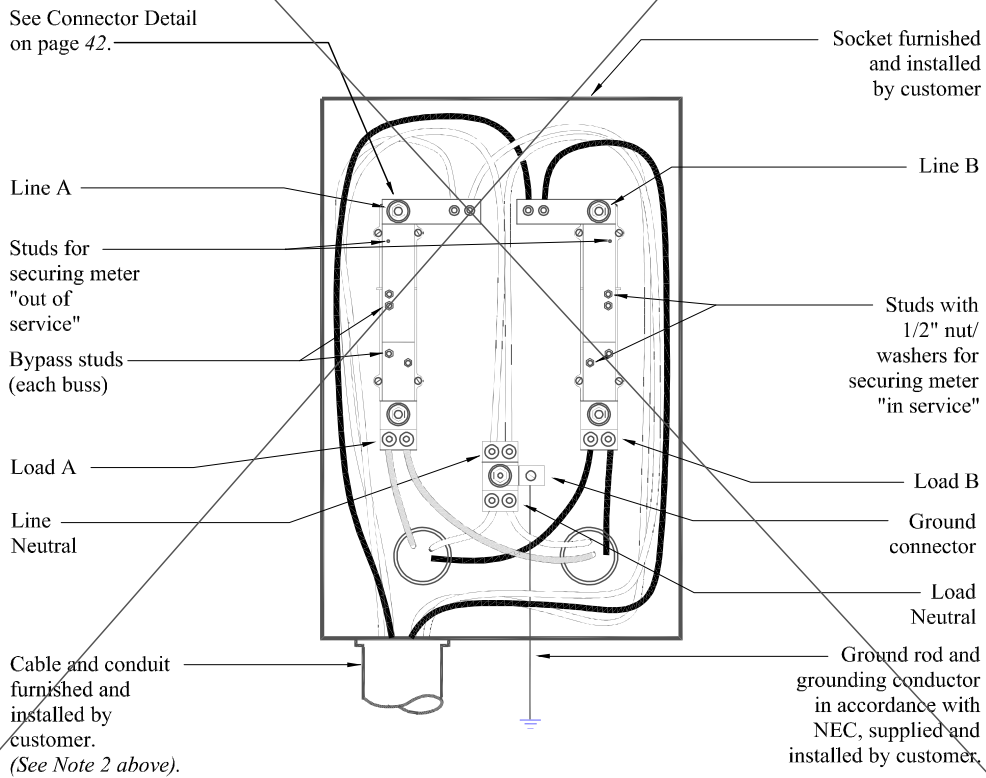

**THIS SOCKET IS NO LONGER AVAILABLE (FOR REFERENCE ONLY)**

**TYPICAL WIRING OF OVERHEAD SINGLE PHASE 480 AMP.,  
SELF CONTAINED, METER SOCKET**

NOTES:

- 1) Self contained meters are applicable where the service entrance conductor capacity is greater than 200 amperes, but not more than 480 amperes continuous. See paragraph 3.8.
- 2) *GRU will furnish and install service conductors for detached single family residential customers only.*

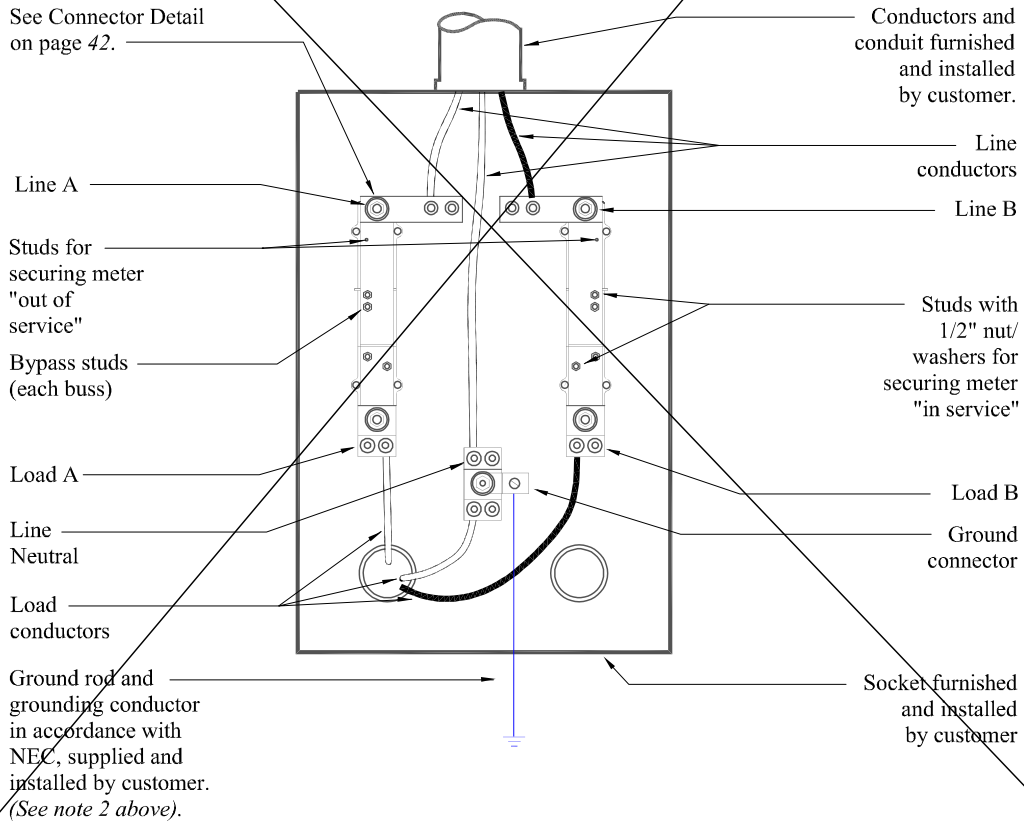

**THIS SOCKET IS NO LONGER AVAILABLE (FOR REFERENCE ONLY)**

**TYPICAL WIRING OF UNDERGROUND THREE PHASE 480 AMP., SELF CONTAINED, METER SOCKET**

**NOTES:**

- 1) Self contained meters are applicable where the service entrance conductor capacity is greater than 200 amperes, but not more than 480 amperes continuous. See paragraph 3.8.
- 2) Services having a voltage rating 277/480 shall have a line side disconnect furnished and installed by the customer, and approved by a qualified employee.
- 3) Line and load conductors furnished and installed by the customer.
- 4) Delta connected services shall have the phase with the higher voltage to ground connected in the right side connector (when viewed from the front.)

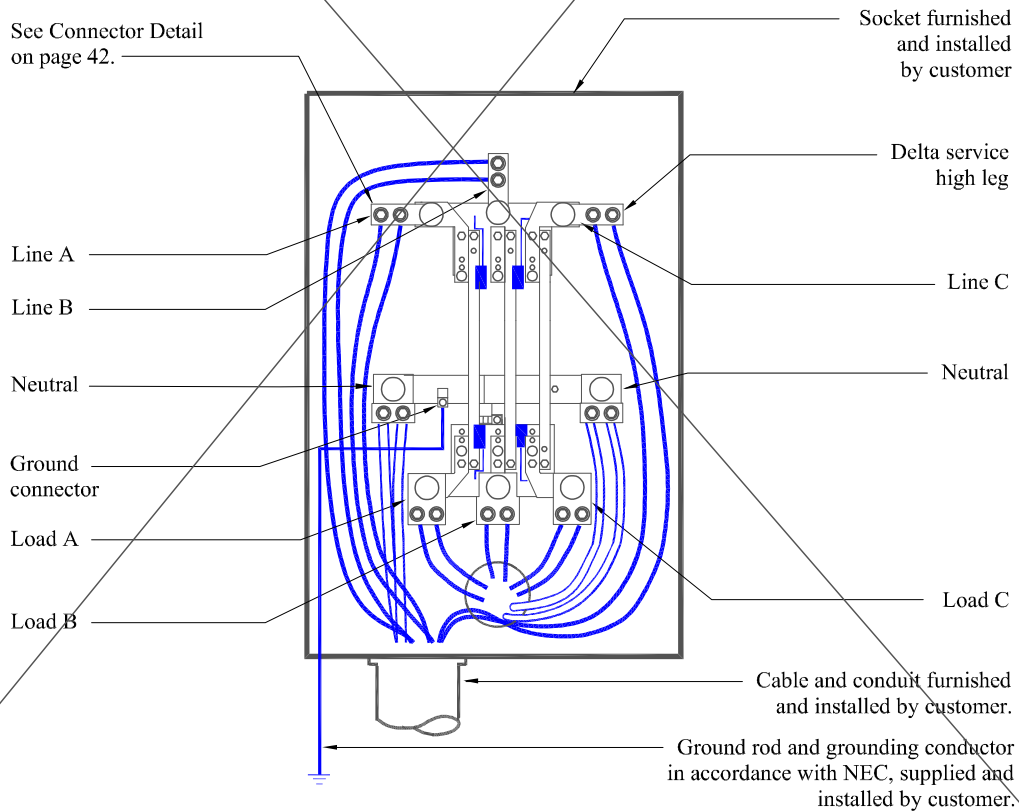

**THIS SOCKET IS NO LONGER AVAILABLE (FOR REFERENCE ONLY)**

**TYPICAL CONNECTOR DETAIL FOR 480 AMP., SELF CONTAINED,  
METER SOCKET**

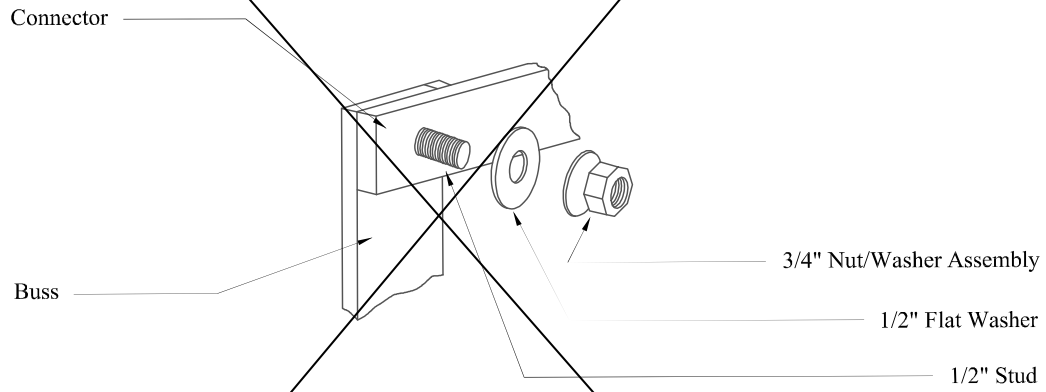

**DELETED (FOR REFERENCE ONLY)**

**TYPICAL WIRING OF SERVICE OVER 400 AMPS. CONTINUOUS,  
USING INSTRUMENT TRANSFORMERS  
(For Single Customer and Single Transformer Only)**

NOTES:

- 1) CT cabinet and socket furnished and installed by customer.
- 2) Socket and CT cabinet shall be grounded at service entrance equipment.

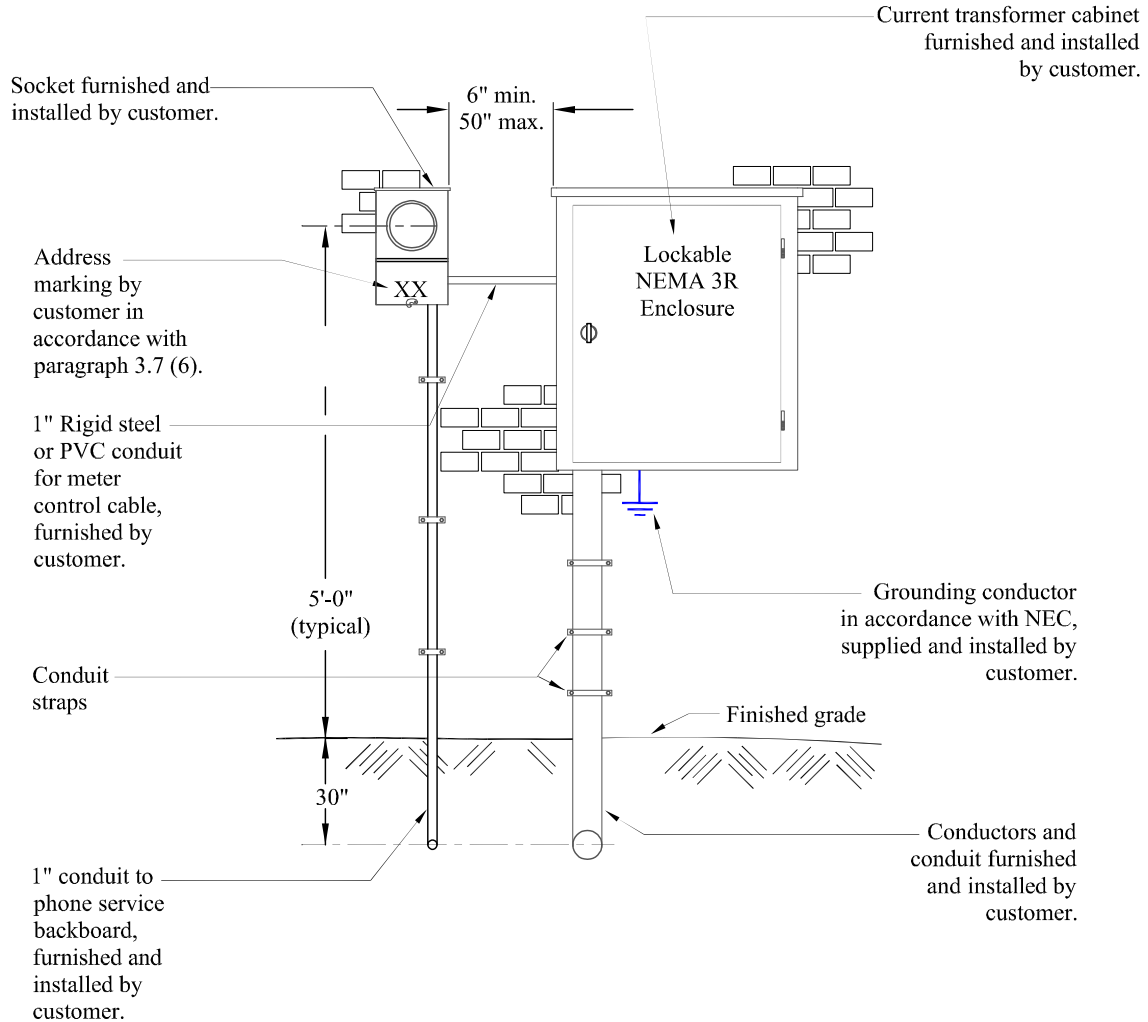

Single Customer and Single Transformer Only

**TYPICAL WIRING OF TWO TO FIVE POSITION METER SOCKET FOR SINGLE PHASE SERVICE**

**NOTES:**

- 1) The customer may furnish and install one (1) multiple position meter socket per building. The socket will have no more than five (5) positions, each rated 200 amperes (nominal), or less. In addition, the fault current at the meter socket shall not exceed 10,000 amperes in accordance with the requirements of paragraph 3.3 (6).
- 2) The customer shall furnish and install a meter center when six (6) or more meter positions are to be served.

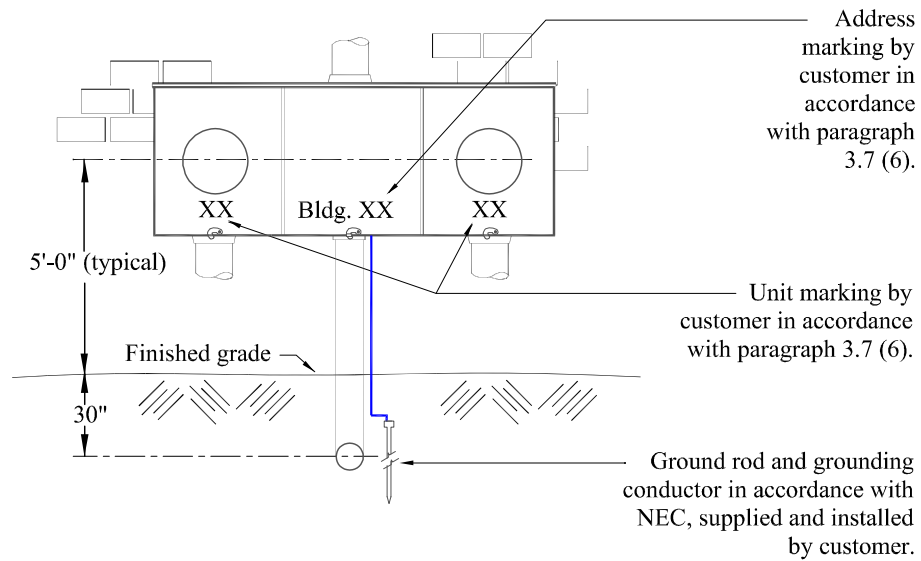
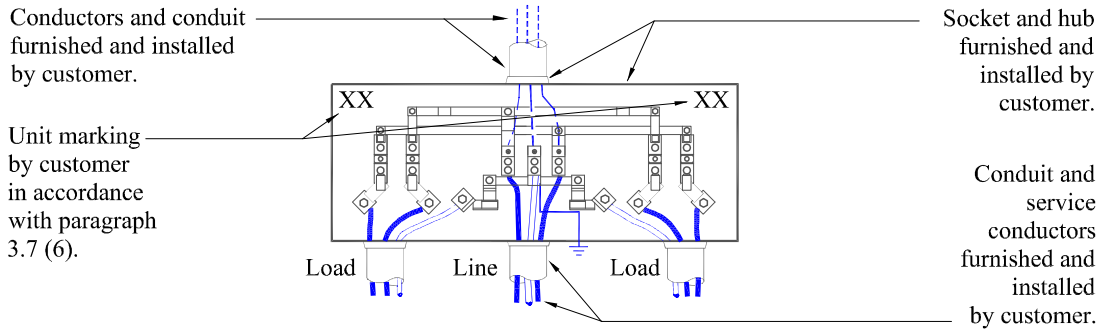

More than five (5) positions requires meter center

**TYPICAL UNDERGROUND MULTI-METERED SERVICE USING A METER CENTER FOR TWO TO SIX POSITIONS**

**NOTES:**

- 1) Meter center furnished and installed by customer.
- 2) Meter centers with ring type design shall be supplied with screw type rings approved by GRU.
- 3) A load side service disconnect and overcurrent device is required when fault currents exceed 10,000 amperes (see paragraph 3.3 (6)).
- 4) When 2 or more meter centers are served by the same transformer a line side disconnect and overcurrent protection is required. This also applies to each meter center per floor in multi-level building applications
- 5) Meter centers shall be UL listed and shall carry a UL label.

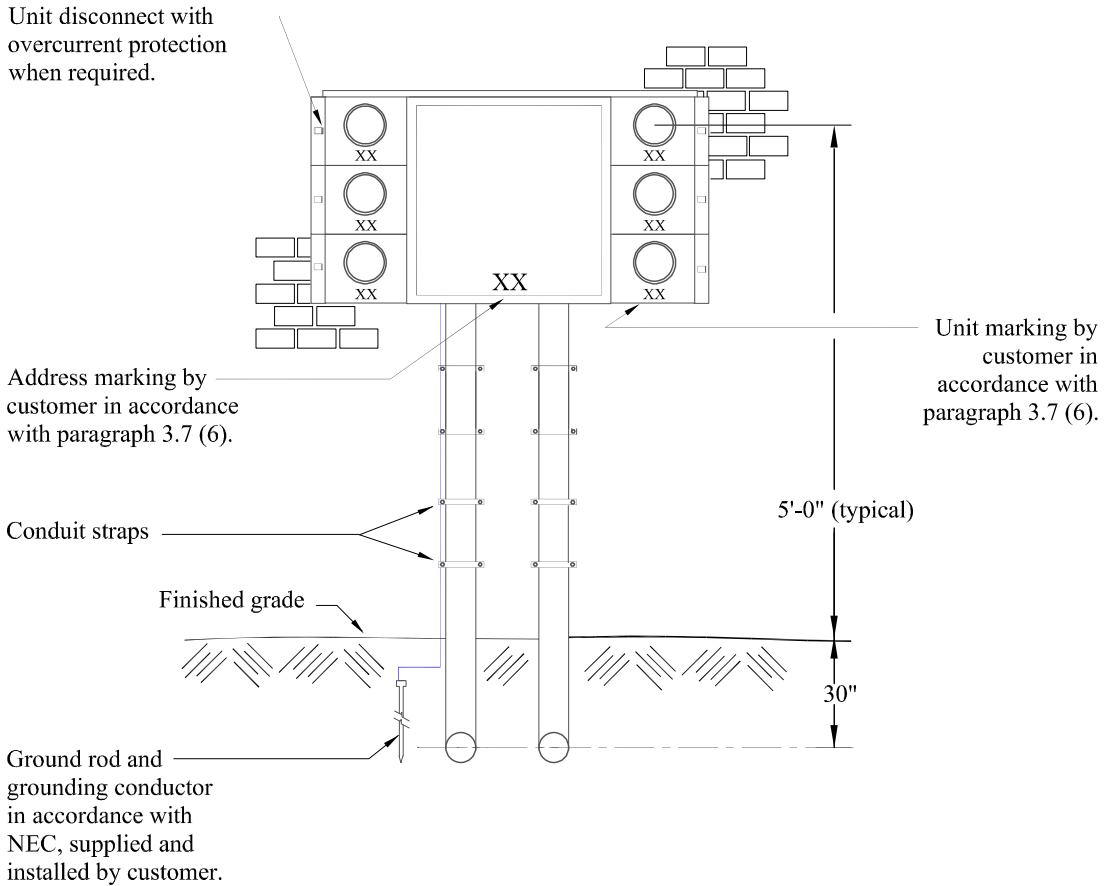

Customer Owned Meter Center Two to Six Positions



**TYPICAL UNDERGROUND MULTI-METERED SERVICE  
USING A METER CENTER OR WHEN INSTALLED INSIDE**

**NOTES:**

- 1) Meter center furnished and installed by customer.
- 2) Meter centers with ring type design shall be supplied with screw type rings approved by GRU.
- 3) Load and Line side disconnect with overcurrent device are required for a single meter center with seven or more positions in single level building applications..
- 4) Line and Load side disconnects and overcurrent devices are required for each meter center per floor in multi-level building applications.
- 5) Meter centers shall be UL listed and shall carry a UL label.

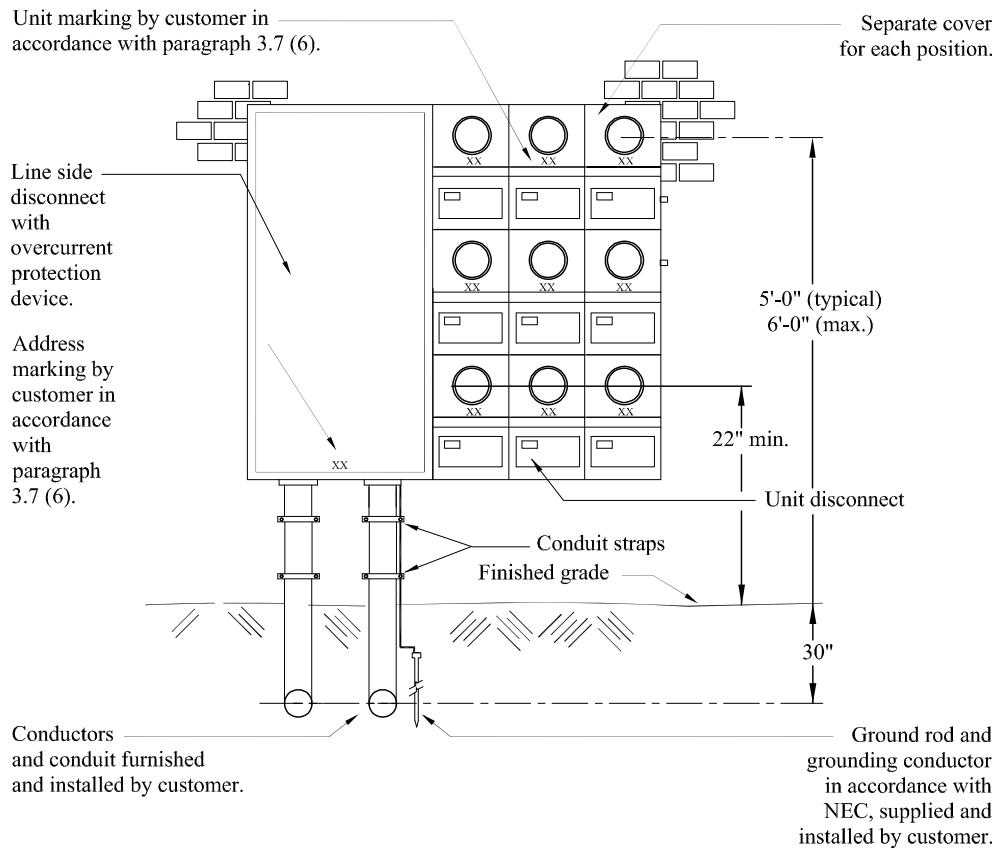

**TYPICAL THREE PHASE, PADMOUNT TRANSFORMER, TRANSFORMER RATED METERING INSTALLATION SERVING ONE CUSTOMER**

**NOTES:**

- 1) Customer may be required to install CT's in a separate compartment at GRU's option.
- 2) Socket and conduit shall be grounded at the transformer ground.
- 3) Metering conduit risers located in areas subject to physical damage, as determined by a qualified GRU employee, shall be rigid steel.

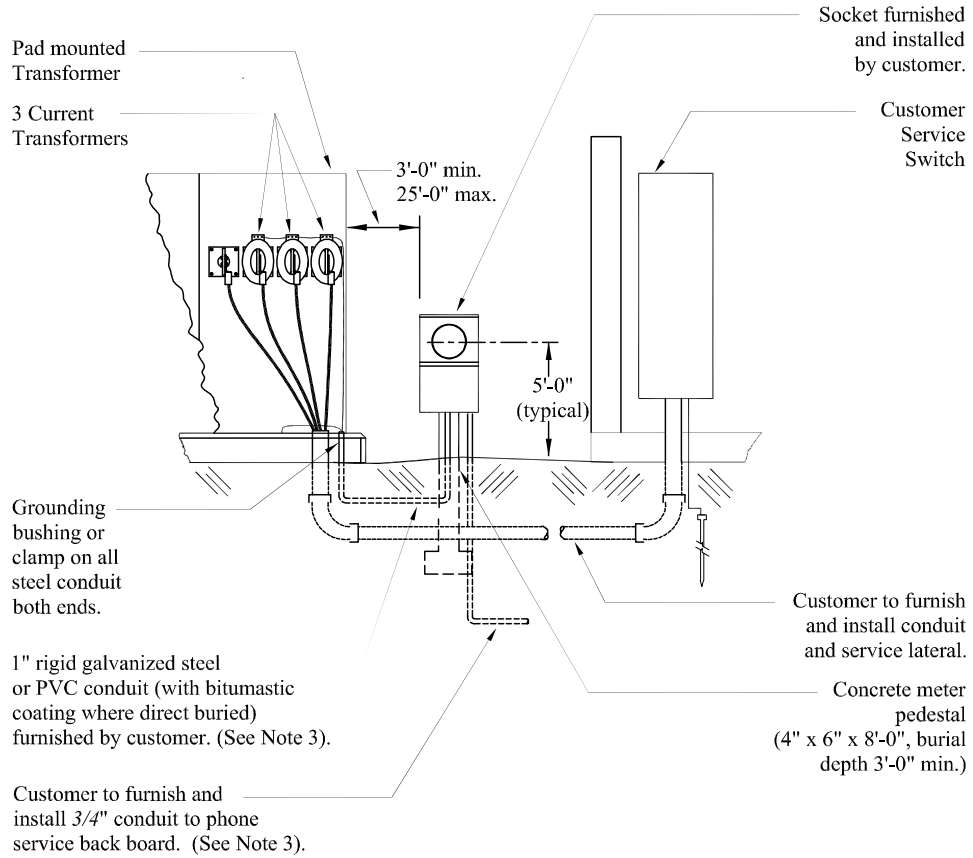

**THIS APPLICATION MUST BE APPROVED BY THE GAS AND ELECTRIC MEASUREMENT (GEM) DIVISION**

**TYPICAL PADMOUNT TRANSFORMER, SERVING MORE THAN ONE CUSTOMER, TRANSFORMER RATED METERING INSTALLATION**

**NOTES:**

- 1) Load side disconnects (with lockable-off capabilities) are required and must be accessible to GRU service personnel, and adjacent to CT cabinet, (outside placement).
- 2) Socket and CT enclosures must be adjacent and readily accessible for the purpose of testing and calibration of metering equipment.
- 3) Metering conduit risers located in areas subject to physical damage, as determined by a qualified GRU employee, shall be rigid steel.
- 4) Disconnecting means furnished and installed by customer with provision for GRU padlock in off position on operating handle.

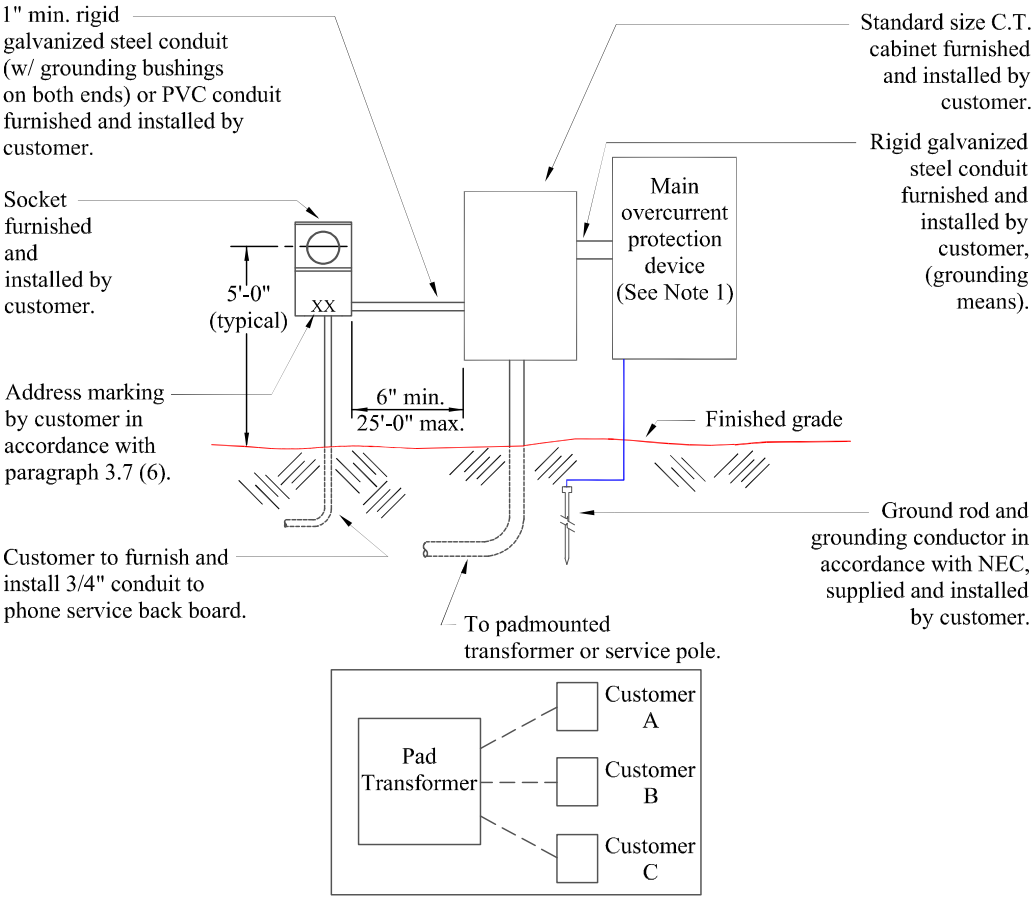

**TYPICAL PADMOUNT TRANSFORMER, METERING INSTALLATION  
SERVING MULTIPLE COMMERCIAL CUSTOMERS FROM A COMMON  
SERVICE LATERAL**

**NOTES:**

- 1) Disconnects shall conform to mounting height provisions of the NEC.
- 2) Disconnecting means furnished and installed by customer with provision for GRU padlock in off position on operating handle.
- 3) This detail is applicable for any multiple meter installation.
- 4) All enclosures carrying unmetered energy shall have means for sealing or locking. See paragraph 2.0 (1).

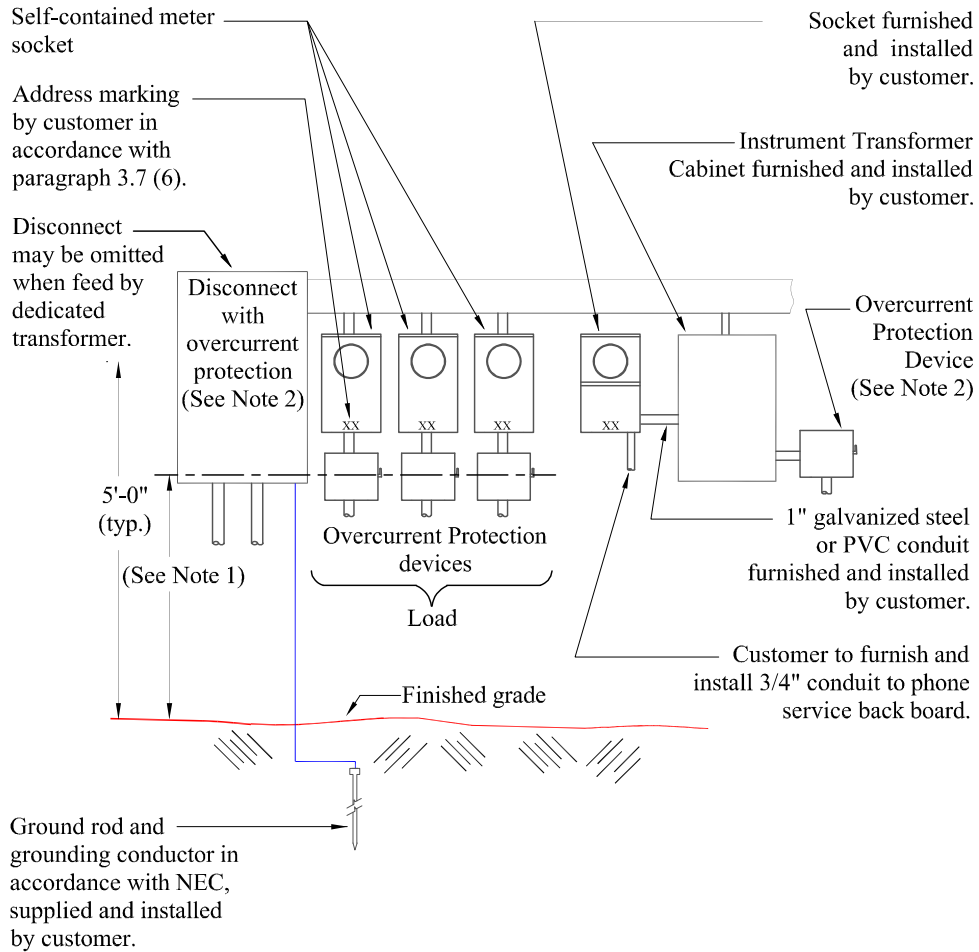

**THIS APPLICATION MUST BE APPROVED BY THE  
GAS AND ELECTRIC MEASUREMENT (GEM) DIVISION**

## TYPICAL OVERHEAD MOBILE HOME SINGLE METER SERVICE

NOTE:

- 1) Service drops minimum clearance (above finished grade):
  - 16' - above residential driveways
  - 18' - above public driveways, alleys and roads

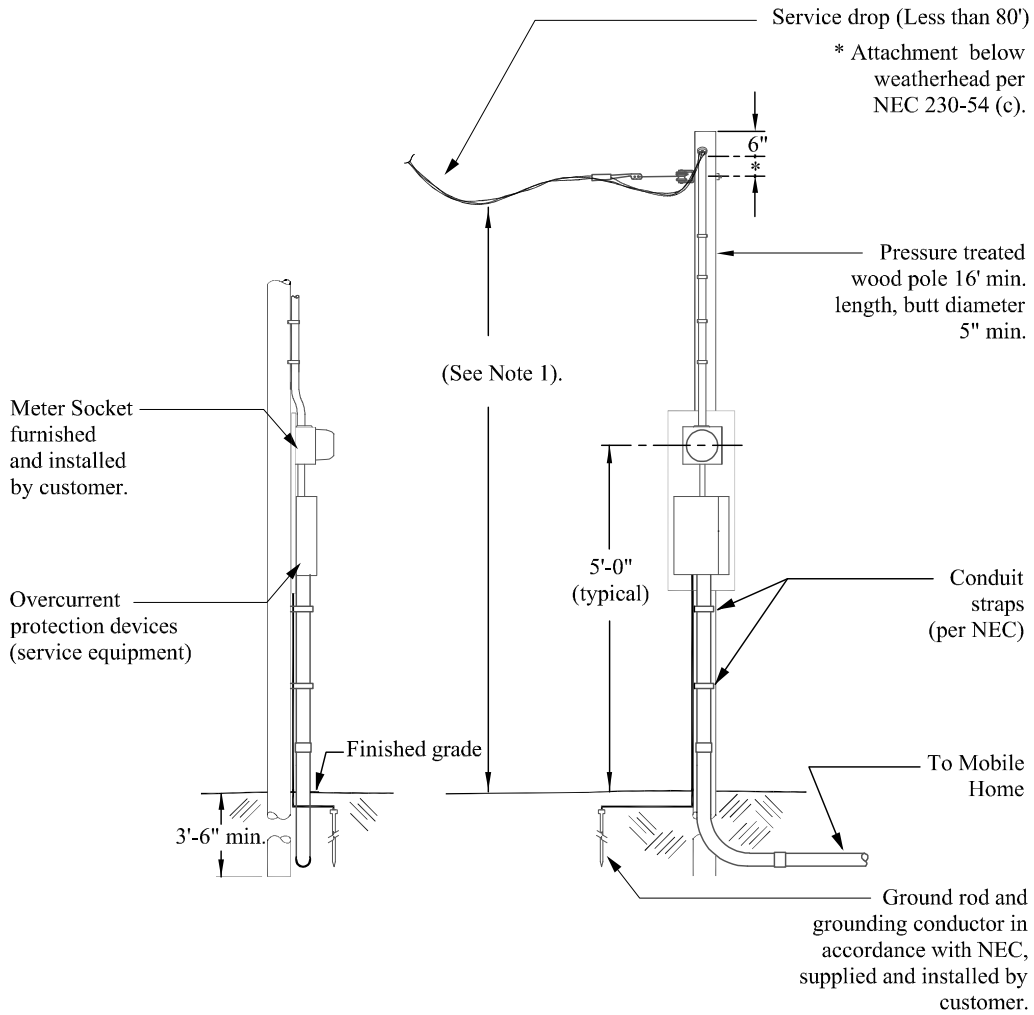

**TYPICAL OVERHEAD MOBILE HOME MULTI-METER SERVICE**

**NOTE:**

- 1) Service drops minimum clearance (above finished grade):
  - 16' - above residential driveways
  - 18' - above public driveways, alleys and roads

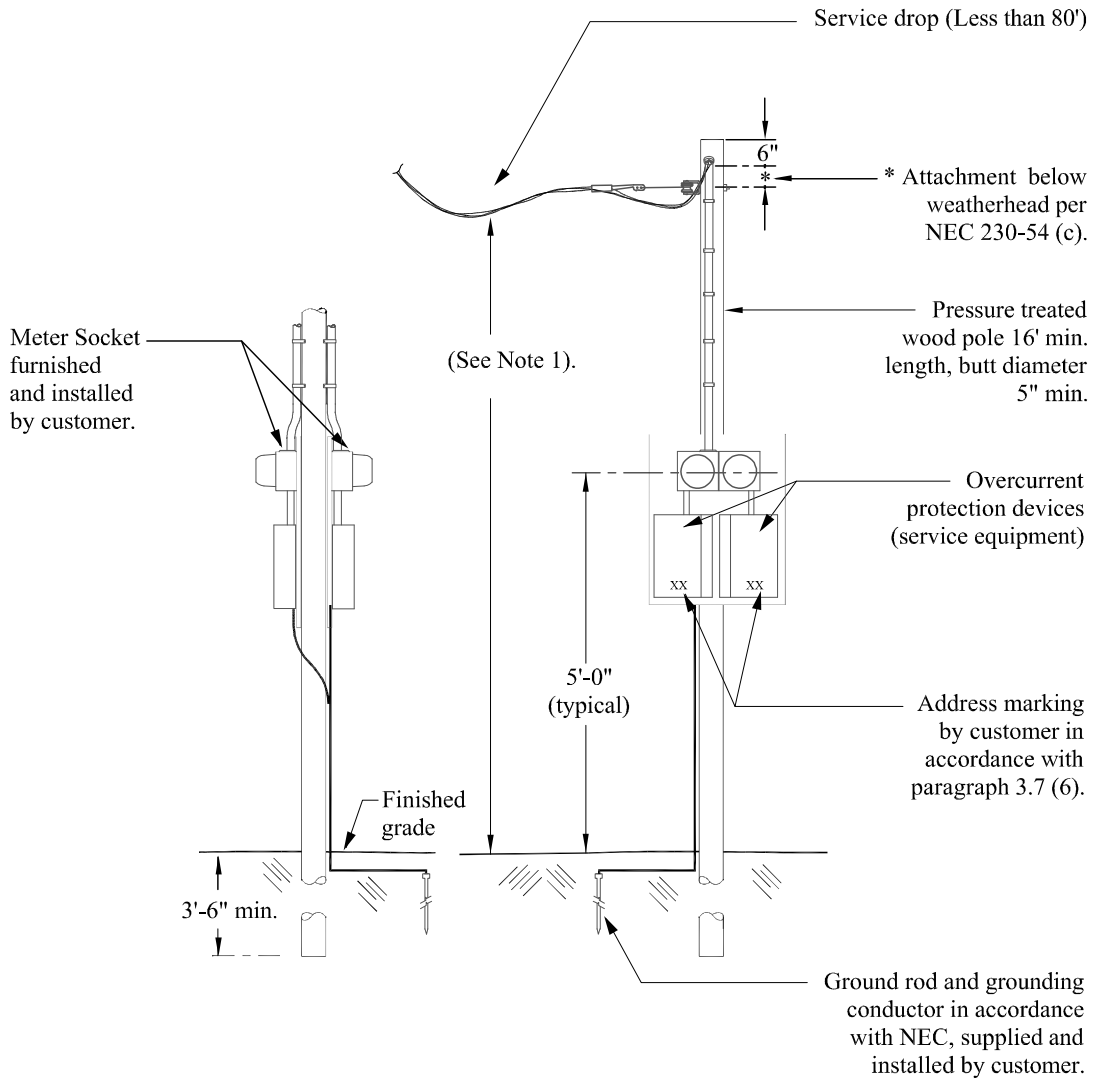

## TYPICAL UNDERGROUND MOBILE HOME SINGLE METER SERVICE

### NOTES:

- 1) Multi-meter services must be identified per paragraph 3.7 (6).
- 2) GRU will furnish and install service conductors for "Detached Single Family Residence" customers only.

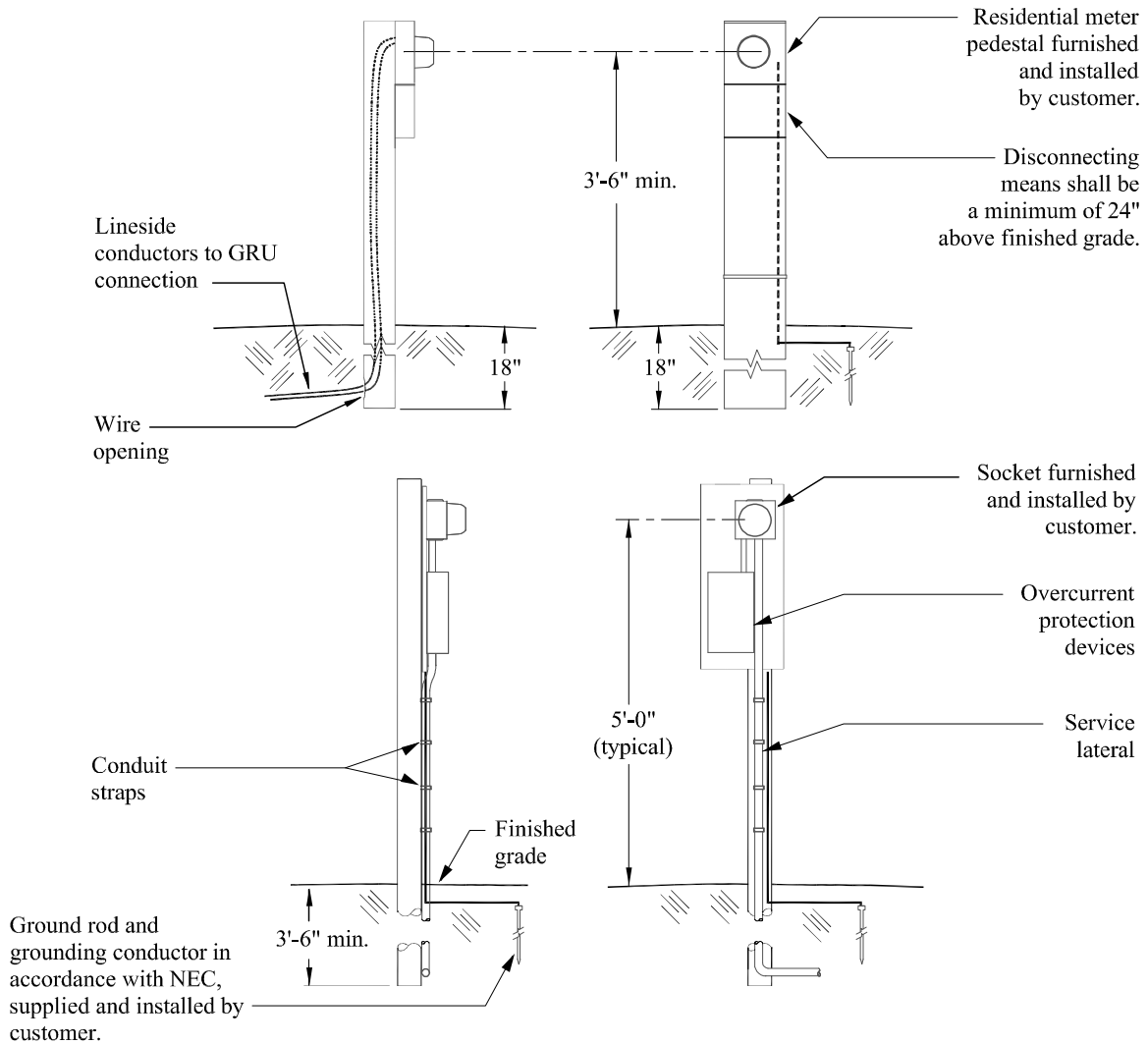

This Page Intentionally Left Blank.



## Section 4: REQUIREMENTS FOR UNDERGROUND SERVICE IN NEW DEVELOPMENTS

### 4.1 General Requirements

- 1) GRU offers underground electric distribution facilities in lieu of overhead facilities for residential and commercial developments with the financial assistance of the developer.
- 2) Underground facilities are offered subject to the availability of funds and personnel. GRU reserves the right to control the scheduling of construction of underground facilities.
- 3) The developer shall furnish the Electric Engineering Dept. with a current survey of existing OH and UG Electric Utilities and infrastructure. A copy of the stamped approved Utility Construction Permit Plan which includes a north arrow. These plans shall be the final design as approved by the City or County and must include the following details:
  - (a) Property boundary lines including individual lot or parcel lines inside the property
  - (b) Topographic lines
  - (c) Easements to be dedicated
  - (d) Paved areas (i.e. streets with center lines, parking and similar areas)
  - (e) Drainage (i.e. storm drains, retention areas)
  - (f) Existing and proposed utilities, (i.e., water, sewer, gas, electric, telephone, or TV cable)
  - (g) Legal property description including, copy of the plat, location sketch, right-of-way lines, Point of Commencement, Point of Beginning, adjoining properties with building/structure outlines, dimensions, and Geodetic coordinates in Florida State Plane north zone/NAD 83 datum (if known)
- 4) The Engineering Division will design an economical underground distribution system, in accordance with GRU's standard construction practices, and that is compatible with existing and planned facilities. The location of all equipment including transformers, switchgear, sectionalizing cabinets, UD service enclosures, UD junction box, service runs and meters will be specified as part of the underground electric system design.
- 5) No permanent overhead electric facilities will be installed in any area to be served by underground electric distribution facilities.
- 6) Ownership of any developer installed conduit system, for a detached single family residential service, will be transferred to GRU upon acceptance. This conduit system must be inspected and approved by the GRU Inspector.
- 7) Primary Underground distribution facilities will be located within or adjacent to the development. All facilities will be installed within easements dedicated to the City by the customer or within the public right-of-way (see section 1, paragraph 1.11).
- 8) Modification of existing facilities required to render service to a development will be billed to the developer in accordance with section 1, paragraph 1.6, and this document.
- 9) The developer is responsible for the clearing and final grading of all public utilities easements and public right-of-ways prior to the installation of electric facilities. All surveying, plan location staking and grade determination for utilities are the responsibility of the developer. All components of the conduit system shall be staked from the Civil Engineering Drawing. (GRU Electrical Drawings are a graphic representation, and shall not be used for scaling or dimensioning). The developer shall insure all utility easements are at and remain at final grade. The developer shall keep all utilities easements clear of construction materials, dirt piles, brush piles, and any other debris at all times.

- 10) Should GRU be required to install temporary overhead facilities in lieu of underground facilities in order to meet its electric service obligations, the costs associated with such temporary work shall be the developer's responsibility.
- 11) The developer will be responsible for additional costs of providing electric facilities incurred in attempting to preserve any natural features, tree(s) or other vegetation.
- 12) All underground primary, secondary, and service conductors shall be installed in a continuous conduit system, as specified by GRU.
- 13) Transformers, primary switchgear and related equipment shall be located in readily accessible areas. (See drawings in Section 1).
- 14) After the construction of GRU's installation is completed, a minimum of 3 business days is required to update GRU's GIS maps. The installation cannot be energized until the GIS map updates have been completed.

#### 4.2 Responsibility for Furnishing and Installing Underground Infrastructure

- 1) Where underground distribution facilities are required by governmental regulations, prudent utility practice, or are requested by the customer or developer, GRU will install underground distribution facilities provided that the customer or developer furnishes and install all conduit, concrete equipment foundations and related civil infrastructure as directed by GRU. All conduit systems and underground enclosures installed by the customer or developer must be inspected by the GRU Inspector for approval.
- 2) The customer or developer will be responsible for the excavation, backfill and final grade of all trenches, including the proper installation of all conduit required (conduit to be supplied by the customer or developer). All Underground facilities must be inspected by GRU prior to backfilling.
- 3) **Commercial and Multi-Unit Buildings:** The customer or developer is responsible for providing the service entrance equipment including the service conductors, conduit(s) and termination enclosures if needed (see Section 2.3 (8)), for all commercial and multi-unit buildings. These facilities shall be owned and maintained by the owner. (See Section 2.3-2) ((b)(c)).
- 4) **Detached Single Family Residence:** The customer or developer is responsible for providing the service entrance equipment and conduit (conduit shall be installed with one piece of continuous pre-lubricated woven polyester pull tape with printed sequential footage markings) for all transformer or underground enclosure to the meter socket (point of delivery), for detached single family residences only. (See Section 2.3 (a)). Ownership of any developer installed conduit system for a detached single family residential service will be transferred to GRU upon acceptance.
  - (a) The detached single family service and secondary conduit shall be sized in accordance with Table I, listed on page 65.
- 5) GRU will furnish, install, and maintain all primary conductors, transformers, switchgear, and related equipment required to render service to a development as provided in these requirements.
- 6) GRU will designate the location of padmounted transformers, the route of primary voltage conductor laterals, and the location of primary voltage switchgear for all developments. (See also paragraph 4.1 (4)).

- 7) GRU will make all primary and secondary/service electrical connections and terminations within transformers and underground enclosures.
- 8) The GRU Gas and Electric Measurement Dept. (GEM) will make the final determination as to type, size and location of all metering installations.
- 9) The size and number of customer or developer installed service conductors that can be connected to one padmounted transformer is limited (see section 2, paragraph 2.4.(7)). Therefore it is essential that the developer/customer consult the Engineering Division well in advance of construction to avoid unnecessary construction delays. The cost of all remedial work shall be borne exclusively by the customer.
- 10) Service conductors installed by the customer or developer will be of sufficient length to allow at minimum a five (5) foot tail to permit the electrical connection to the padmounted transformer, or other equipment.
- 11) For underground non-residential services that originate from an overhead secondary source, the customer will furnish and install the conduits, conductors and underground enclosure from the customer's equipment to the customer installed underground enclosure at the base of the pole. GRU will make the connections in the underground enclosure and will take over ownership and maintenance of the underground enclosure upon acceptance. The customer or developer will furnish GRU with a sufficient length of conductor to make the permanent electrical connections.

**Table I: Conduit Sizes for Underground Secondary Cable**

NOMINAL SIZE CODEWORD	CABLE DIAMETER	WEIGHT LBS. PER 1000'	CONDUIT SIZE (PVC)
6/3	0.648"	135	1-1/2"
1/0-1/0-2 Brenau	1.106"	387	2-1/2"
4/0-4/0-2/0 Sweetbriar	1.421"	709	2-1/2"
350-350-4/0 Wesleyan	1.795"	1118	3"
500-500-300 Brooklyn	2.065"	1544	3"
4/0-4/0-4/0-2/0 Wake Forest	1.588"	993	3"
350-350-350-4/0 Slippery Rock	2.006"	1582	4"
500-500-500-350 Wafford	2.363"	2231	4"

## UNDERGROUND RESIDENTIAL SERVICE

### NOTES:

- 1) GRU approved meter sockets furnished and installed by customer. (Approved GRU materials found in Energy Delivery Service Guide Appendices).
- 2) All connections in the transformer will be made by GRU.
- 3) Ownership of any customer installed conduit system (except the Meter Riser Conduit) for a detached single family residential service will be transferred to GRU upon acceptance. □
- 4) See Section 2, page 28, for the drawing showing the dimensional details for an Underground Residential Single Family Detached installation.

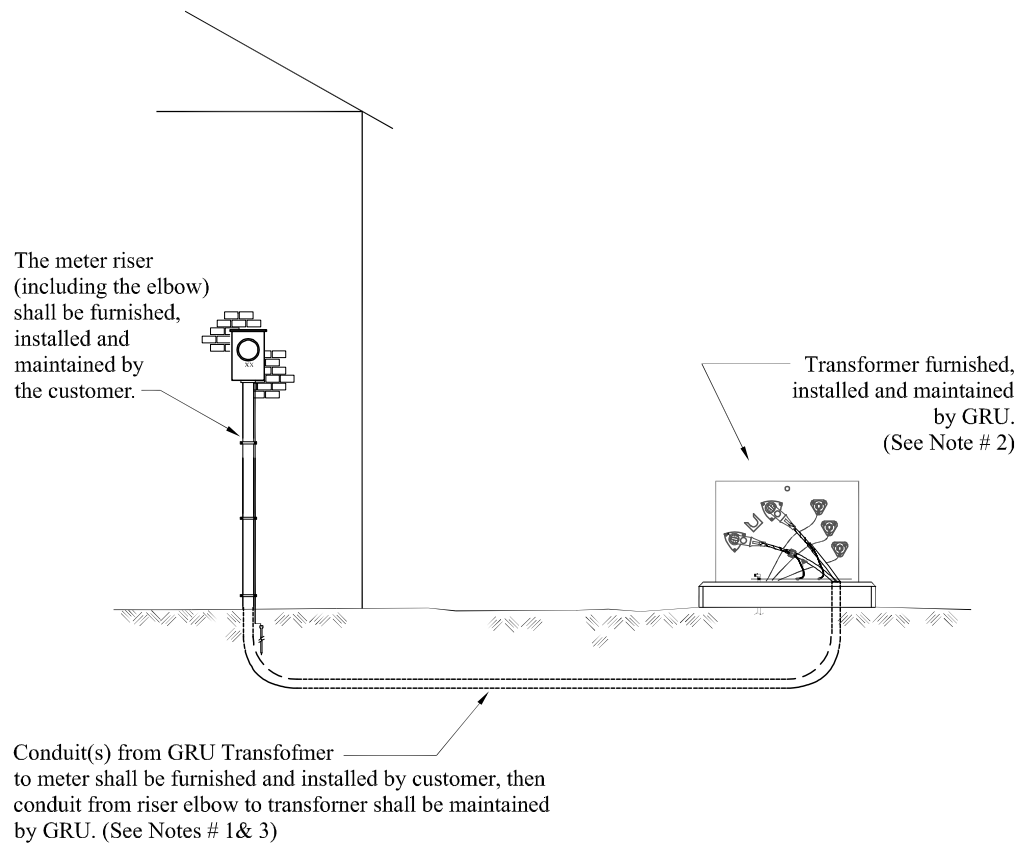

**UNDERGROUND RESIDENTIAL SERVICE WITH AN UNDERGROUND ENCLOSURE/PEDESTAL (When Applicable)**

**NOTES:**

- 1) GRU approved meter socket, conduit (from meter to Service Enclosure) and Service Enclosure are furnished and installed by customer. (Approved GRU materials found in Energy Delivery Service Guide Appendices).
- 2) All connections in the transformer and underground enclosures/pedestals will be made by GRU.
- 3) Ownership of any customer installed conduit system (except the Meter Riser Conduit) for a detached single family residential service will be transferred to GRU upon acceptance. □
- 4) See Section 2, page 30, for the drawing showing the dimensional details for an Underground Residential Single Family Detached installation.

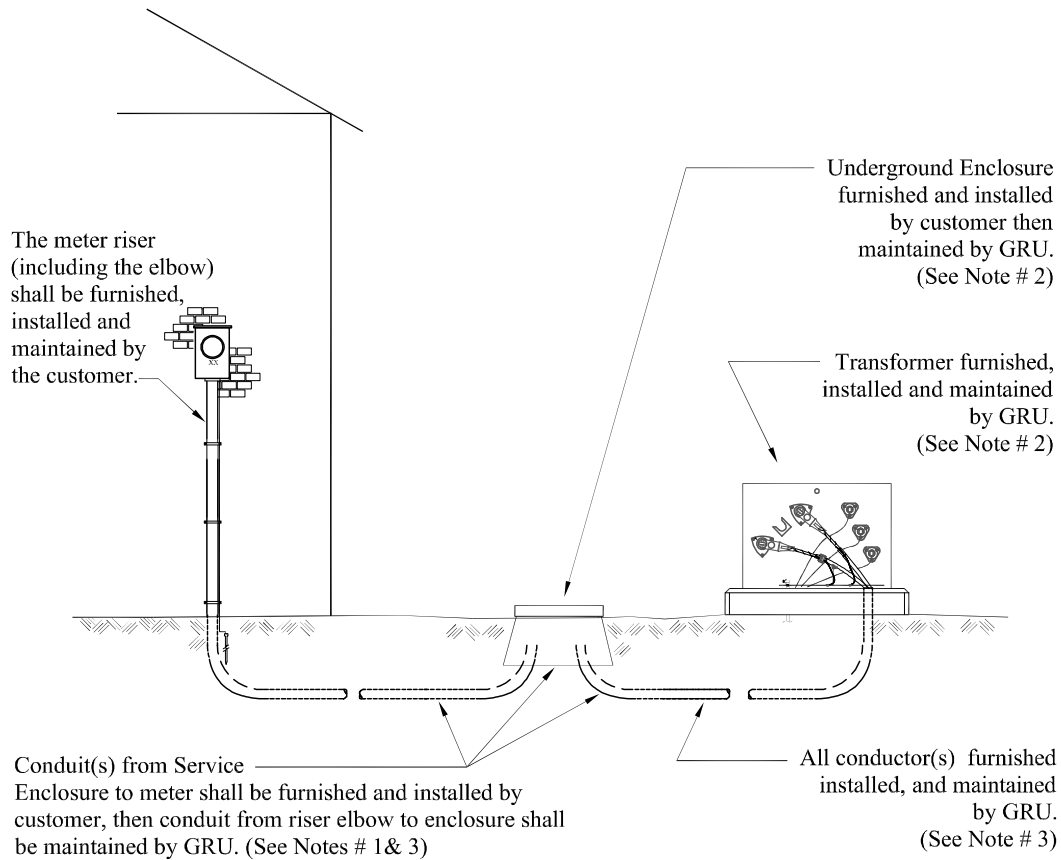

## UNDERGROUND NON-RESIDENTIAL SERVICE

### NOTES:

- 1) GRU approved meter center furnished, installed and maintained by customer.
- 2) Meter centers with ring type design shall be supplied by customer with screw type rings approved by GRU.
- 3) Line side disconnect with overcurrent device is required.
- 4) Load side service disconnects and overcurrent devices are required.
- 5) All conductors and conduits will be furnished, installed and maintained by customer
- 6) All customer owned and maintained utilities, (electric, natural gas, water, wastewater, reclaimed water and telecommunications), location requirements are the responsibility of the customer and **will not be located by GRU.**
- 7) All connections in the transformer will be made by GRU

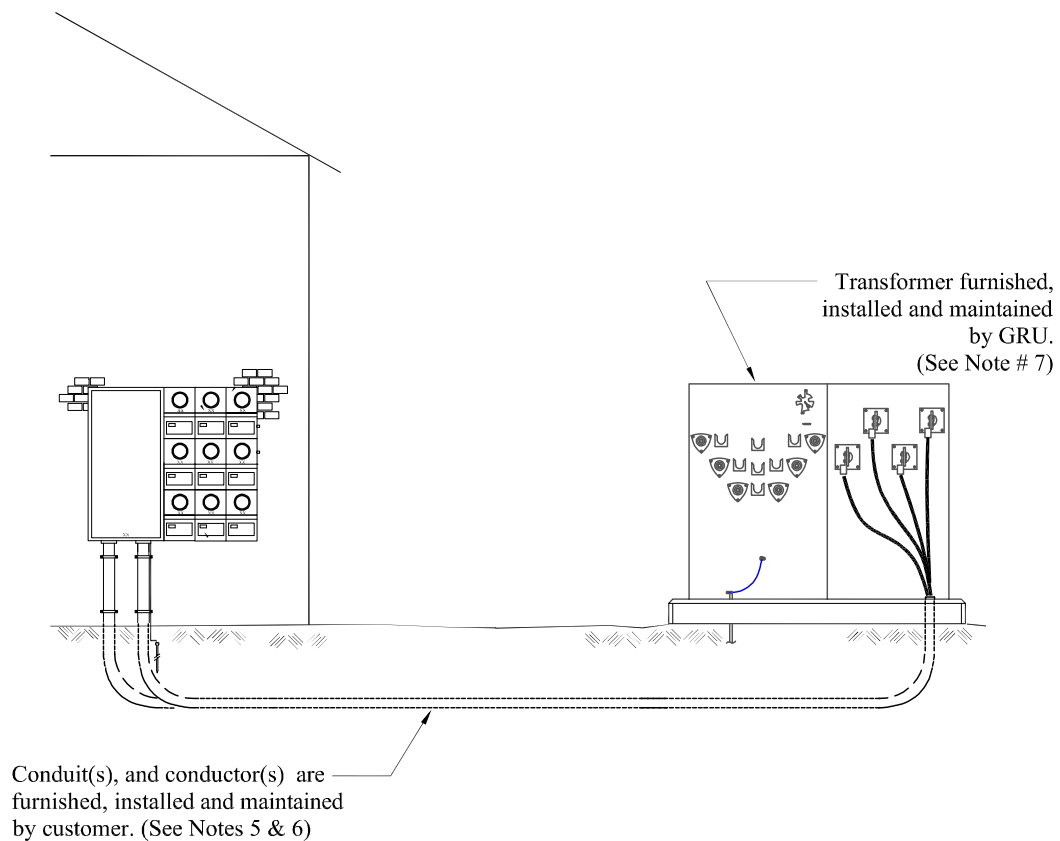

## ALTERNATIVE UNDERGROUND MULTI-METERED SERVICE USING A METER CENTER AND A TERMINATION ENCLOSURE

### NOTES:

- 1) GRU approved Meter center furnished and installed and maintained by customer.
- 2) Meter centers with ring type design shall be supplied by customer with screw type rings approved by GRU.
- 3) Line side disconnect with overcurrent device is required.
- 4) Load side service disconnects and overcurrent devices are required.
- 5) All connections in the Termination Enclosure will be made by the customer.
- 6) All customer owned and maintained utilities, (electric, natural gas, water, wastewater, reclaimed water and telecommunications), location requirements are the responsibility of the customer and **will not be located by GRU.**
- 7) All connections in the transformer will be made by GRU.

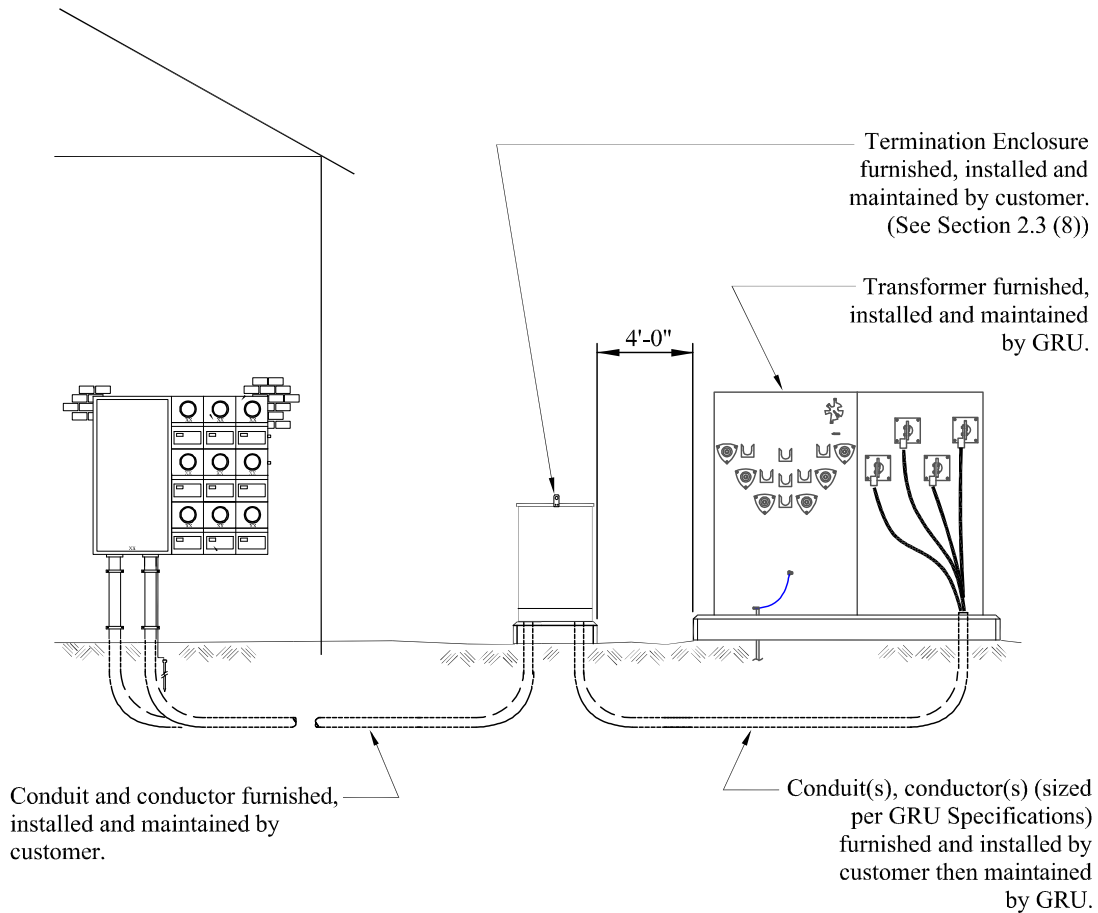

**THIS APPLICATION MUST BE APPROVED BY THE GRU  
ENERGY DELIVERY ELECTRICAL ENGINEERING DIVISION**

This Page Intentionally Left Blank.



## **Section 5: PRIMARY VOLTAGE AND SPECIAL SERVICE CONDITIONS**

### **5.1 Installations at Primary Distribution Voltages**

- 1) Service at more than 600 volts, nominal, is subject to special negotiations between the and GRU since the metering and service installations for such service require special engineering customer consideration. It is always advisable to consult GRU well in advance of the time such service will be required so the customer and GRU's design and construction work can be properly coordinated.
- 2) Primary (high) voltage service for large power or transmission rate customers will be supplied at a standard voltage provided that a 400 kW demand will be realized and high voltage is available at the customer's location.
- 3) Primary (high) voltage service will be supplied from the nearest suitable high voltage facility. The customer shall contact the Engineering Division to arrange for the construction of facilities necessary to provide such service.
- 4) All primary (high) voltage services must incorporate overcurrent protective device(s) to isolate GRU from the customer's facilities during fault or excessive load conditions on the customer's service. GRU will approve the protective device prior to installation. The physical point of installation shall be designated by GRU, in consultation with the customer, typically at the point of delivery.
- 5) The interrupting capacity of all protective devices shall be rated for the fault current available at the customer's location as determined by the Engineering Division.
- 6) The customer's loads shall be balanced as equally as possible among all three phases to minimize the impact of the service on GRU's primary distribution and transmission systems.
- 7) After the construction of GRU's installation is completed, a minimum of 3 business days is required to update GRU's GIS maps. The installation cannot be energized until the GIS map updates have been completed.

### **5.2 Standby and Parallel Generators**

- 1) Improperly installed generation equipment can create serious hazards for GRU personnel working on the distribution system, as well as for customers connected to the distribution system. The operation of improperly installed generators can also result in damage to customer's wiring, electrical equipment or the generator itself. To safeguard against these hazards, customer owned generators shall be installed as follows:
  - (a) Standby generators shall be installed in compliance with the National Electrical Code and local codes. They shall be properly connected through transfer switches so they are completely isolated from GRU's distribution system. Power from a standby generator must never be supplied to another premises because of the danger created by back-feeding into the distribution system.
  - (b) Generators designed to run parallel with GRU's system require special protective devices. It is essential the customers consult the Engineering Division regarding these protective requirements before installing or operating parallel generators.
  - (c) Generators shall be installed a minimum of fifteen (15) feet from the GRU Transformer, with the Generator Engine positioned farthest from the GRU Transformer, and a minimum of ten (10) feet from any building. The GRU Transformer shall be installed with the front (doors) facing away from the generator.
  - (d) Connection of any privately owned power production source (solar, generators, batteries, wind, etc.) to a utility connected electrical system shall NOT be made, at any point in the system (load or line), by the use of self-piercing or insulation piercing taps.

- 2) Customer installations that include standby generation shall be connected to GRU's Distribution System solely through a double throw transition switch (break before make) which insures absolute isolation between GRU and the customer's generator. Such installations shall be inspected and approved by the Engineering Division prior to the rendering of service. GRU reserves the right to disconnect any installation that fails to comply with the provisions of this article.

### **5.3 Motors**

- 1) Single phase, 120 volt motors having a locked-rotor current less than 40 amperes and single phase, 240 volt motors having a locked-rotor current less than 100 amperes may normally be started at line voltage without problems.
- 2) Single phase motors having locked-rotor currents exceeding the limits in paragraph (1) may require special service considerations, and a qualified employee should be consulted before purchasing or connecting such motors.
- 3) Because allowable locked-rotor currents vary at different locations, a qualified employee should be consulted before connecting polyphase motors to GRU's distribution system.
- 4) Starting compensator's, auto starters, or equivalent apparatus shall be required for single phase motors of 5 hp or more and three phase motors of 10 hp or more. The purpose of this requirement is to limit starting inrush currents to values that will minimize objectionable voltage fluctuations (flicker) to other customers.
  - (a) For motors in excess of 7-1/2 hp GRU reserves the right to designate the number of phases and voltage at which the motor will be served.
  - (b) GRU may waive the motor starter requirement when the motor is run in a continuous mode (not more than one start daily), when a motor is not operated on a daily basis or when other operating conditions as determined by a qualified employee do not adversely affect voltage on the distribution system. Any customer desiring a waiver of the motor starter requirement shall submit a written request to the Engineering Division for special permission to waive this requirement.
  - (c) GRU reserves the right to revoke a waiver of the motor starter requirement at any time, should any present or future nearby customer experience excessive voltage flicker attributable to the operation of the motor.

### **5.4 Operating Characteristics**

The operating characteristics of some customer equipment can adversely affect GRU's distribution system. Such equipment includes, but is not limited to: electric welders, electric furnaces, and x-ray equipment, radio and television transmitters. GRU may require the customer to furnish and install special equipment to mitigate the impact of operating equipment with objectionable characteristics.

### **5.5 Transformer Vault Requirements**

GRU's standard method of providing electric service for commercial and industrial installations is to install a padmounted, three-phase transformer outdoors within an easement on the Owner's property. GRU recognizes that there may be situations where the Owner/Developer has limited outside space available to install a padmounted transformer. In this event the Owner/Developer may request that the transformer be installed in an indoor transformer vault. In this situation the Owner/Developer must contact GRU Energy Delivery early on in the design process to coordinate all the design elements prior to final plan approval.

**Please Note:**

the installation of a transformer in a vault is a costly option for the customer and GRU, due to the special transformer and room requirements needed by the building code. This section addresses the requirements for installation of a GRU padmounted transformer in a building vault.

- 1) Due to the high water table in GRU's service territory, GRU will not furnish or install transformers in a below grade vault.
- 2) GRU will provide primary meter service for any electric installation not conforming to GRU's Standard installation requirements or the requirements of this section. If the primary meter option is selected, the Owner/Developer is responsible for furnishing, installing and maintaining all electric facilities behind the primary meter. The primary meter installation and equipment location shall be coordinated with GRU Energy Delivery.
- 3) The Owner/Developer must construct the building vault in accordance with the applicable sections of the National Electrical Code, National Electrical Safety Code, Southern Building Code, and all State and Local building and fire codes. The local inspection authority having jurisdiction must inspect the vault. In addition, the vault must also meet all of GRU's requirements before GRU will connect and energize the building's electric service.
- 4) A licensed Architect or Professional Engineer shall design the transformer vault. The design drawings and calculations shall be submitted to GRU for acceptance prior to site plan approval.
- 5) The Owner/Developer shall furnish all relevant information about the vault construction, including but is not limited to: detailed floor plan, plot plan showing the location of the proposed vault and truck access location, switchgear locations, electric load calculations, proposed meter and conduit and/or raceway locations. The design information should be provided to GRU well in advance of the start of construction. GRU Energy Delivery must accept the design and location of the vault.
- 6) Where an entrance door is required (in addition to transformer access doors) the entrance door to the vault must lead directly to an outside area and the vault entrance must be readily accessible to GRU personnel for inspection and maintenance 24 hours per day without involving a second party. The door must be equipped with an emergency release to allow the door to be readily and quickly opened in case of an emergency. The Owner/Developer must place "High Voltage" warning sign on the outside door in a conspicuous location. The door lock must be capable of being opened by a GRU system key. The vault lock may be either a dead bolt lock or a hasp capable of receiving a GRU system padlock.
- 7) The transformer must be readily accessible by doors, readily removable louvers or other readily removable architectural systems large enough to remove or install the largest transformer. This entrance must allow access to GRU construction vehicles for removal or maintenance of the transformer. Access should be located at ground level. The transformer access door height must be sufficient to allow a crane or boom access into the vault. Minimum height shall be 10 feet.
- 8) The Owner/Developer is responsible for all lighting within the vault. Minimum maintained lighting level is 25 foot-candles. The fixtures are normally mounted on the ceiling and above the transformer. The light switch shall be mounted adjacent to the entrance door. A minimum of 2-120 volt GFI protected electrical outlets is required within the vault. Maintenance of the lights and electrical outlets is the responsibility of the Owner/Developer.

- 9) The vault ventilation system shall be designed to allow adequate airflow to dissipate the transformer's full load (nameplate) heat losses without exceeding the design temperature rise of the transformer at full load. Overloaded transformers will require additional ventilation. Contact GRU Energy Delivery for transformer data and kVA size. The clear vent area must be at least 3 square inches per kVA (3 sq. In=0.021 sq. ft.). The Clear Vent Area required (CVA) in square feet is calculated as follows:

$$\text{CVA} = (\text{kVA}) (.021)$$

The total vent area required in square feet is calculated as follows:

$$\text{Total Vent Area} = \text{NCVA} / \text{A}$$

Where A is the percent efficiency (expressed as a decimal) of grating, screens, louvers etc.

The ventilation openings shall be designed and located to prevent insertion of sticks, wires, rods, etc. that could contact any exposed live electrical equipment. Provisions for additional ventilation should be considered in the original design to account for any future increase in electrical demand. Maintenance of any forced ventilation fans, ventilation filters etc. is the responsibility of the Owner/Developer. The design temperature of the cooling air (ambient temperature) of the vault shall be 35 degrees Celsius. The upper limit of the cooling air shall not exceed 40 degrees Celsius in the vault and the average temperature of the cooling air for any 24 hour period shall not exceed 30 degrees Celsius.

- 10) The Owner/Developer shall contact GRU Energy Delivery Engineering for the maximum volume of oil that must be contained within the vault.
- 11) The transformer vault shall be constructed and maintained as a dry environment. The vault shall provide adequate structural strength in the floor to support the transformer. Contact GRU Energy Delivery Engineering for transformer weight and dimensions.
- 12) The vault must be sufficiently large to provide safe access and working space for the operation and maintenance of all electrical equipment. The following are the requirements for the vault construction:
  - (a) Vault floor size shall be 15'-0" wide by 12'-0" deep (One size for all GRU Transformers. See drawings on pages 78 thru 80).
  - (b) Ceiling height shall be 12'-0"
  - (c) A lockable rollup metal door, 12'-0" wide by 10'-0" high. (See drawings on pages 79 thru 81).
  - (d) The entrance to the Vault/Room must be paved to allow GRU trucks, forklifts and installation equipment a level and hard surface to work from.
  - (e) Provisions for a ground rod shall be placed in front of the transformer, (See paragraph 5.5, (13), and drawings on pages 78 thru 80).
  - (f) Oil containment shall be accomplished with a grated mote area around the perimeter of the vault. (See on drawings pages 78 thru 80).
  - (g) The primary power conduits shall be steel. These conduits must be tied into the grounding system in the vault. Contact GRU Energy Delivery Engineering for both primary and secondary conduit entrance locations.

- 13) The Owner/Developer shall install a 1-1/2 inch PVC conduit through the vault floor for a GRU ground rod. The area under this PVC shall be free of any obstructions that could prevent the installation of the ground rod. Failure to install this conduit in an approved location will require the Owner/Developer to drill a 1-1/2 inch diameter hole through the vault floor. A 4/0 copper ground bus may have to be installed within the vault. Grounding requirements are to be coordinated with GRU Energy Delivery Engineering.
- 14) The Owner/Developer shall install four (4) - 4" \*PVC or steel conduits from the transformer to a connection point specified by GRU. The primary conduits shall enter the transformer vault from underground. The primary and secondary feed may enter the transformer from overhead or underground, (See on drawings pages 78 thru 80). All conduit shall be installed with one piece of continuous pre-lubricated woven polyester pull tape with printed sequential footage markings. Contact GRU Energy Delivery Engineering for both primary and secondary conduit entrance locations.
  - \* **Note:** Five feet minimum, 8 feet maximum of steel conduit shall extend above the finished floor of the transformer vault when the transformer is to be feed from overhead. (See drawing on page 79).
  - (a) Underground feed transformers: Primary and secondary conduit shall be terminated into the air compartment of the transformer for underground feeds. Contact GRU Energy Delivery Engineering to coordinate the locations for the primary and secondary conduits.
  - (b) Overhead feed transformers: Contact GRU Energy Delivery Engineering to coordinate both primary and secondary conduit entrance locations. Cable racks shall be installed over the transformer to support the overhead primary cables. Bus Bar shall be used to connect secondaries to the transformer.
- 15) The Owner/Developer is responsible for furnishing and installing all secondary conductors from the transformer to the service entrance equipment. The maximum number of conductors that GRU's transformer can accommodate is 8 sets of 750 MCM installed in conduit, raceway, or by bus bar.
- 16) The Owner/Developer shall grant GRU and easement for all cable and conduits from GRU facilities to the transformer vault. The Owner/Developer shall grant GRU the right of ingress and egress to the transformer vault for the purpose of installing and maintaining GRU facilities.
- 17) The Owner/Developer is responsible for the Fire Protection design and installation. The Fire Protection must meet the requirements of the National Electrical Code and State and Local fire protection requirements. Typically the vault must be constructed of materials (usually 6" concrete walls) with a minimum fire resistance of 3 hours. Contact the National, State and Local authorities for the minimum fire wall rating and acceptable construction materials. GRU's transformers are filled with mineral oil that is not considered a "less-flammable" material. Contact GRU Energy Delivery for the fire point and flash point of the oil used in the transformer.
  - (a) GRU can provide a transformer filled with a "less flammable" liquid. The additional cost for providing the "less flammable" liquid is the responsibility of the Owner/Developer. Contact GRU Energy Delivery Engineering as soon as possible if this option is required due to the long lead times (120 weeks) in obtaining a transformer from the manufacturer. Contact GRU Energy Delivery Engineering for the additional costs, and the fire and the flash point for the "less flammable" liquid.

- 18) GRU will provide current transformers in the transformer for metering purposes. The Owner/Developer is responsible for installing a 1-inch galvanized steel or schedule 40 PVC conduit from the transformer to the meter location. In some cases a 1-inch conduit will be required to be installed from the transformer to the telephone backboard. Contact GRU Energy Delivery Engineering to coordinate the meter location and communication conduit installation.
- 19) The vault shall not be used for any purpose other than to house and protect GRU's transformer and associated equipment. No conduit or piping for water, sanitary plumbing, and gas supply or for any other purposes shall pass through the transformer vault.

**Three Phase Transformer Vault/Room Design  
(Constructed by the Customer)**

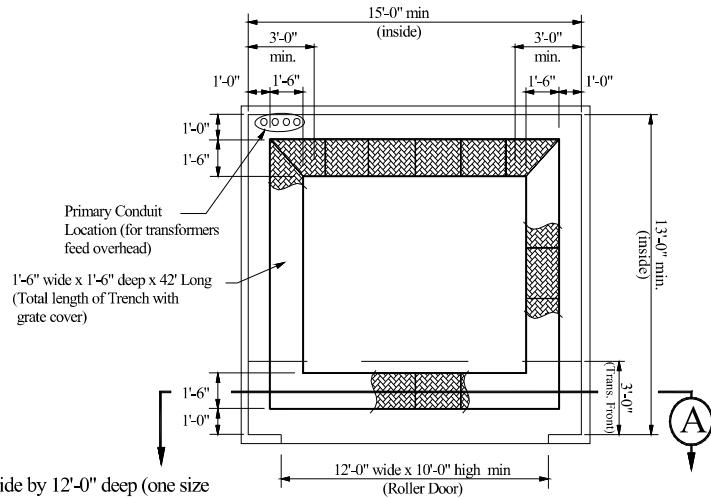

**Vault Plan View**

**General Notes:**

- 1) Vault floor size 15'-0" wide by 12'-0" deep (one size for all GRU transformers) See drawing.
- 2) Ceiling height 12'-0".
- 3) Lockable rollup metal door shall be 12'-0" wide by 10'-0" high. See drawing.
- 4) Grounding (ground rod) shall be placed in front of the the transformer.
- \*\*5) Transformer oil shall be a "less flammable" material which will be at the owners expense.
- 6) Oil containment shall be accomplished with a grated mote area around the perimeter of the vault. (This will eliminate the doorsill). See drawing.
- 7) The primary power conduits shall be steel. These conduits must be tied into the grounding system in the vault.
- \*8) Cable Racks shall be installed over the transformer to support the overhead primary cables.
- \*9) Buss Bar shall be used to connect Secondaries to the transformer.
- \* Note: These two requirements are for transformers that the primary and secondary conductors are feed from overhead.

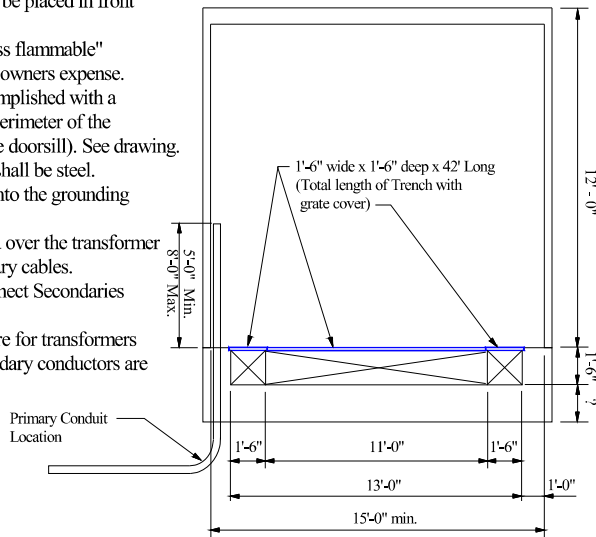

**Detail A - Elevation View**

**Three Phase Transformer Vault/Room Equipment Layout  
For Overhead Primary and Secondary Feeds**

**\*\* (Transformer Supplied by GRU Purchased by the Customer)**

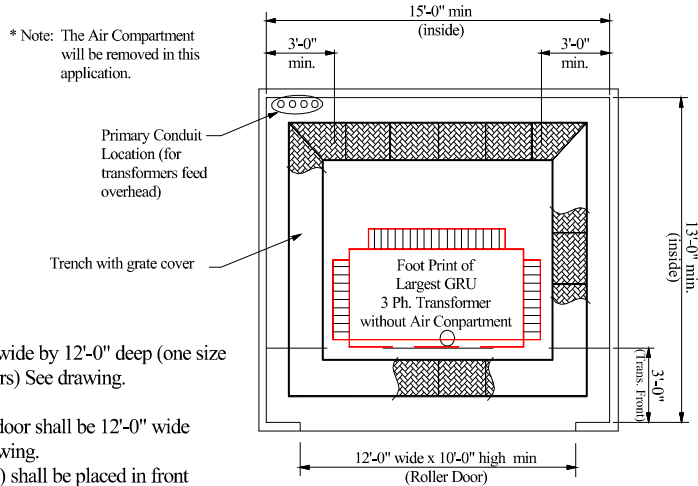

**Equipment Plan View**

**General Notes:**

- 1) Vault floor size 15'-0" wide by 12'-0" deep (one size for all GRU transformers) See drawing.
- 2) Ceiling height 12'-0".
- 3) Lockable rollup metal door shall be 12'-0" wide by 10'-0" high. See drawing.
- 4) Grounding (ground rod) shall be placed in front of the transformer.
- \*\*5) Transformer oil shall be a "less flammable" material which will be at the owners expense.
- 6) Oil containment shall be accomplished with a grated mote area around the perimeter of the vault. (This will eliminate the doorsill). See drawing.
- 7) The primary power conduits shall be steel. These conduits must be tied into the grounding system in the vault.
- \* 8) Cable Racks shall be installed over the transformer to support the overhead primary cables.
- \* 9) Buss Bar shall be used to connect Secondaries to the transformer.
- \* Note: These two requirements are for transformers that the primary and secondary conductors are feed from overhead.

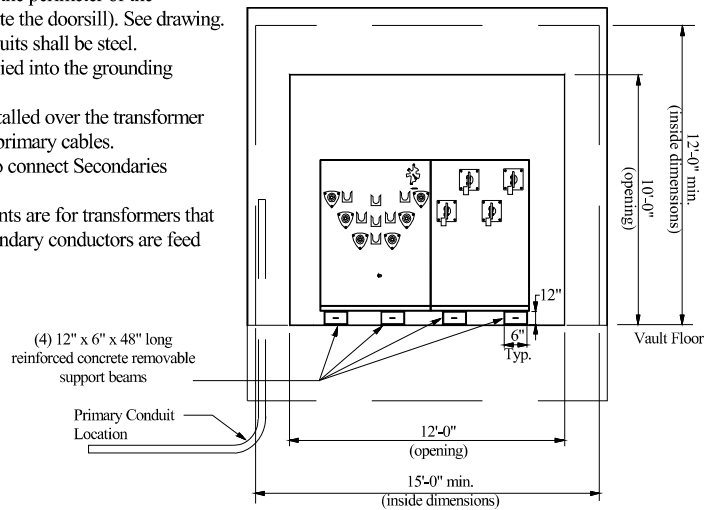

**Equipment Elevation View**



This Page Intentionally Left Blank.

## **Section 6: LIGHTING SERVICE**

### **6.1 Service Categories**

- 1) GRU offers two categories of lighting service; public agency sponsored lighting services (public lighting) and rental lighting service (rental lighting).
- 2) As of October 1, 2019, all new lights offered by GRU will be LED (light emitting diode) Lights. As published in “City of Gainesville Code of Ordinances”, Appendix A-Schedule of Fees, Rates and Charges.
- 3) GRU will install lighting on any public right-of-way, or other public property upon written authorization from the City or County agency having jurisdiction.
- 4) GRU installs rental lights on private property upon request by individual customers.
- 5) Lighting rates are published in, “City of Gainesville Code of Ordinances”, Appendix A Schedule of Fees, Rates and Charges.
- 6) Should a department of the City of Gainesville or Alachua County or a private customer request to install pole(s) or lighting fixture(s) not approved in the Gainesville Regional Utilities Electric Material Standards, the fixture(s), wiring, and lighting component(s) shall be connected behind a meter. The purchase, installation of all materials, operation, maintenance and ownership of the pole(s), fixture(s), wiring, and lighting component(s) behind the meter will be the responsibility of the requesting department or customer. The energy charge for the lighting shall be at the general service non-demand rate. Refer to “City of Gainesville Code of Ordinances”, Appendix A-Schedule of Fees, Rates and Charges, subsections m., or n., or p.

### **6.2 Requesting Public Lighting Service**

- 1) Within the City of Gainesville, the city’s Traffic Engineering Department will review all requests for public street lighting. They will authorize GRU to install public street lighting based on their assessment of need and the availability of funds. Refer to Section 27-29 (b) of the “City of Gainesville Code of Ordinances”.
- 2) Within the unincorporated areas of Alachua County, the County Engineer will review all requests for public street lighting. They will authorize GRU to install public street lighting based on their assessment of need and the availability of funds. Refer to Section 27-29 C) of the “City of Gainesville Code of Ordinances”.

### **6.3 Requesting Rental Lighting Service**

- 1) GRU will furnish rental lights to any property owner after a Rental Light Service Contract has been submitted. The Rental Light Service Contract is available on the GRU Web Site (at [www/gru.com](http://www/gru.com).) upon written application, a monthly fee will be charged for this service. The customer must contract with GRU to keep the rental light(s) and, if required, pole(s), as applicable, for a minimum of five (5) years. Failure to adhere to the five (5) year provision will require the customer to pay a fee for the early removal of facilities as prescribed by Gainesville Code of Ordinances. Refer to Section 27-30 and 27-30.1 of the “City of Gainesville Code of Ordinances”.
- 2) The style and type of lighting available may vary, contact Electric Engineering Dept. for a complete listing.

#### **6.4 Requirements for Public Lighting Service**

- 1) All public lighting services shall be requested from GRU and authorized by the appropriate city or county agency (see paragraph 6.2 above).
- 2) Lighting levels will conform to applicable lighting guidelines.
- 3) The Electric Engineering Dept. will provide technical assistance and cost estimates to the requesting agency for all proposed street and area lighting installations
- 4) The style and type of lighting available may vary, contact Electric Engineering Dept. for a complete listing.
- 5) Lighting installations that incur extraordinary expense (i.e., underground construction, primary and/or secondary facilities expansion, dedicated transformers, and similar equipment) will be constructed provided that the agency authorizing the installation furnishes and installs the required conduit and pays all extraordinary costs in a lump sum prior to construction of the project.
- 6) GRU will bill the appropriate agencies monthly for street lights and poles in accordance with the rates prescribed by the City of Gainesville Code of Ordinances, Appendix A.

#### **6.5 Requirements for Rental Lighting Service**

- 1) Rental lighting will conform to appropriate local ordinance and GRU guidelines for roadway and/or area illumination.
- 2) Rental lights in areas with overhead electrical distribution facilities will normally be served overhead. Similarly, rental lights in areas with underground facilities will be served underground.
- 3) GRU will furnish rental light installations including standard poles provided that the customer requesting installation has agreed to the monthly rental fee for those poles in accordance with the rates in the City of Gainesville Code of Ordinances, Appendix A.
- 4) Non-standard luminaires and poles may be installed on metered services only. The purchase, installation of all materials, operation, maintenance and ownership of the pole(s), luminaire(s), wiring, and lighting component(s) behind the meter will be the responsibility of the requesting customer. Non-standard luminaire may not be installed on GRU poles.
- 5) Rental light installations that incur extraordinary expense, (i.e. underground construction, primary and/or secondary facilities expansion, dedicated transformers, and similar equipment) will be constructed provided that the customer requesting such work furnishes and installs the required conduit and pays all extraordinary costs for such installations. A prepayment equal to the estimated cost will be required prior to the ordering materials and/or the start of construction
- 6) Premature removal fees will be charged for any change of luminaire and/or pole (type or size) requested by the customer within the initial five (5) year contract. The customer must also initiate a new five (5) year contract for any newly requested facilities.
- 7) The cost of relocating rental lights and/or related facilities shall be paid in full to GRU before work will be performed in the following circumstances:

- (a) If the facilities are relocated on the same premises at the requests of the customer.
- (b) If the facilities must be relocated due to actions by or on behalf of the customer.
- 8) GRU will bill the customer monthly for each rental light in accordance with the rates in the "City of Gainesville Code of Ordinances"
- 9) GRU will retain ownership of all rental lights (lights not behind a meter) and will provide the normal maintenance required to operate those lights effectively.

**6.6 Information for Developers/Contractors Requesting Lighting**

- 1) GRU will furnish lighting upon written request by the developer/contractor. Such lighting installations can be of two forms:
  - (a) Rental Light Rate Class: This class of light rates are lights used by a commercial, industrial or residential customer where the monthly rental rate is paid for by the customer. The monthly Rental Light Rate includes all materials including wire, the cost of installation, maintenance and energy of the light(s). The rental rate for lights does not include the rental rate of a \*\*pole to support the light. If a pole is necessary to support a rental light a separate pole rental rate shall be charged in addition to light rental rate. The monthly Pole Rental Rate includes all materials including wire, the cost of installation and maintenance of the pole(s). The pole shall also be rented under this same class.
  - (b) Rental Agency Light Rate Class: This class of light rates are lights used by a commercial, industrial or residential customer and the monthly rental rate is paid for by the customer. The monthly Rental Agency rate, which allows the agency to "Buy Down" the rental rate, includes the energy charge and normal maintenance cost ONLY. The rates for lights do not include the installation of \*\*poles. The installation cost (materials, including wire, GRU engineering, construction cost and overheads) for lights and poles (if needed) shall be paid for up front by the customer responsible for the monthly rental charges prior to installation by GRU. The ownership of the lights and poles remains with GRU.

**\*\* GRU Rental Lights may be installed on GRU distribution poles or GRU Rental Light Poles ONLY.**

Reference: Appendix A, UTILITIES Electricity: Section m. Paragraphs 1. and 2.

- 2) Requests for public street lighting must be approved by the appropriate public agency.
- 3) Lights in areas with overhead electrical distribution facilities will be served overhead. Similarly, lights in areas with underground facilities will be served underground. All lighting will conform to GRU guide lines for the specific application, unless otherwise directed by the appropriate public agency.
- 4) In developments to be served underground, the developer shall furnish and install all conduit (conduit shall be installed with one piece of continuous pre-lubricated woven polyester pull tape with printed sequential footage markings). The developer is strongly advised to contact the Electric Engineering Dept. well in advance of construction to insure that any proposed lighting system will be incorporated into the design of the underground electrical distribution facilities. The concurrent use of trench and transformers and other equipment will help minimize the cost to the developer. The ongoing costs associated with a lighting system installation will be based on the categorization of the lights as either public or rental.

## **6.7 Maintenance and Repair**

- 1) GRU will repair luminaires upon notification as provided by the type of Rental Light Service Contract for that customer.
- 2) Luminaires and/or poles that require repeated repairs due to vandalism will be removed to avoid excessive maintenance costs. When maintenance problems due to vandalism occur GRU will notify the customer or agency of its intent to remove the lighting equipment. The customer or agency will have the option of continuing service if it agrees to pay all excess maintenance expenses resulting from vandalism as determined by GRU.
- 3) GRU will trim vegetation for the installation of lights and for access to repair existing light heads. City of Gainesville Public Works will trim vegetation for illumination around public streetlights within the city limits. The county department of public works will trim vegetation for illumination around public streetlights within the county. Vegetation trimming around rental streetlights on private streets within developments, apartment complexes and on private property, can be provided by a private tree-trimming contractor hired by the development, apartment complex or private renter. GRU is not responsible for trimming vegetation around installed Public or Rental Lights for illumination.

## Section 7: NATURAL GAS SERVICE

### 7.1 General Information:

- 1) Permits and Inspection -  
It is necessary that the construction of new or remodeled buildings conform to provisions of city and county ordinances and rules. GRU will establish gas service after the customer installed gas piping facilities are satisfactorily installed, inspected and all necessary permits have been obtained.
- 2) Application for Service -  
Requests for service require advance planning by GRU in order to serve the connected load. Large capacity gas meters may require extended lead-time for delivery from the manufacturer. It is important that GRU be provided, as early as possible, with accurate load information and the expected date the customer will require service. This will enable GRU to make all the necessary arrangements for the service and metering facilities in a timely manner.
- 3) Service Connections -  
Service to customers is normally established at one delivery point, through one meter. The service is designed to extend from the connection on the distribution facilities along the shortest, most practical route to the delivery point. The service delivery point is the point of connection between GRU facilities and the customer's gas piping system. Some commercial and multiple family buildings may be served at more than one point of delivery. In these instances, GRU should be consulted to approve additional points of delivery. Only authorized GRU employees may connect or disconnect GRU gas service to a building or structure. Call GRU if it is necessary to have the service disconnected or the meter removed.
- 4) Delivery Pressure -
  - (a) Standard delivery Pressure to our gas customers shall be either seven inches (7") water column or two (2) psig for Natural Gas. For propane (LP) installations, delivery pressure shall be eleven inches (11") water column or two (2) psig. It is important to note that only one gas pressure will be delivered to the outlet side of the meter that is connected to customer-owned house piping. Elevated delivery pressure may be provided when requested and indicated in the contract for services; however gas pressure inside the building shall not exceed two (2) psig for residential installations under normal operating conditions.
  - (b) For large volume commercial/industrial installations, when a customer has requested an elevated delivery pressure entering a building or structure greater than 2 psig, the request must be approved by the Energy Delivery Officer (EDO) or his/her designee. All installations approved to exceed two (2) psig shall be installed in accordance to NFPA 54, Florida Fuel Gas Code, and/or applicable local building codes.
- 5) Changes in Requirements-  
Some of the information contained in this section is based on governmental codes and ordinances, which are subject to change as determined by the appropriate authority. GRU does not assume responsibility for keeping information in this book current with governmental codes, ordinances or other requirements. GRU should be consulted in case of doubt regarding the applicability of information contained in this section.
- 6) Change of Customer's Load or Equipment-  
A customer or contractor must notify GRU of any plans to make an appreciable change in the amount or character of the gas load served by GRU. This information is required by GRU to ensure that metering and service facilities are sized to accommodate the anticipated load.

## 7.2 Typical Gas Service Installation

This section covers typical gas service requirements for residential, small commercial and small industrial installations. Large loads, in excess of 1 MCFH, and utilization of elevated delivery pressures will be handled on an individual basis.

### 1) General Requirements -

- (a) The installation of services, including meter and primary regulator will be furnished by GRU. In those cases where a gas main must be extended to provide service, GRU will provide service upon the completion of a favorable economic analysis. Additionally, services that are exceptionally long or cost prohibitive will be analyzed on an individual basis (see paragraph 1.5 (5)).
- (b) Gas service lines will not be installed under or through buildings or embedded in concrete. Service lines should not be installed under paved areas or driveways. If there is no alternative to locating a gas service line under a driveway, sidewalk or other area to be paved, the service should be installed before the area is paved. Notify GRU as early as possible of any planned paving. A sleeve for the gas service line installation may be required. When paving around the gas service riser, the customer is to provide an opening or free space in the paving for the riser. The opening is to be a minimum of 4 inches in diameter, unless otherwise specified.
- (c) If the electric service is to be installed underground, the gas service line and the electric service may be installed in a common trench or joint trench (see Appendices D pages D-4, D-5, D-6, D-7 and D-8). A joint trench may include telephone and cable television facilities. Arrangements for joint trench installations involving telephone, cable television or other facilities requires lead-time. Ensure that GRU has reviewed and approved all trench details before trenching. The typical service trench design is shown on page 91.
- (d) Electrical bonding to or use of GRU gas service lines, gas risers or meter facilities for electric grounding is not permitted.
- (e) Customers are responsible for the cost of relocating gas service facilities when they construct a building or add on to a building where GRU facilities are located (see paragraph 1.6 (2)).

## 7.3 Gas Meter Location

- 1) The gas meter set includes the gas meter, service regulator, riser valve, all associated above-ground GRU piping and fittings, and overpressure protection devices. Unless specific approval is obtained, the gas meter set will be located outside.
- 2) All meter locations are subject to GRU approval. A satisfactory meter location can best be determined if GRU is contacted during the planning stage for a new or remodeled building. In cases where multiple meters are required, GRU will furnish meter set dimensions.
  - (a) The gas meter set will be located so that the regulator vent maintains 36 inches of separation from any source of ignition. See pages 88, 89 and 90, for typical gas meter set and separation requirements.
- 3) Meter set locations that are subject to damage from vehicular traffic require protection which must be furnished by the applicant. GRU shall determine when such protection is required. Physical protection must be provided for all gas meter sets located in the following areas. (See Appendices D page D-29).

- (a) Within 3 feet of single-family residential driveways, parking areas, commercial refuse container locations, thoroughfares or paved areas with curbs.
- (b) Within 8 feet of multifamily, commercial/industrial driveways, parking area, loading docks, freight handling areas, thoroughfares or paved areas without curbs

4) Prohibited Meter Locations

- (a) In living quarters or garages.
- (b) Behind fences or other barriers that the customer can lock. GRU personnel must have access to the customer's premises at all times for the purpose of installing, reading, inspecting, repairing, removing, replacing, disconnecting, or otherwise maintaining its electric or gas meters, equipment, and facilities.
- (c) Under display platforms or show windows in commercial buildings where the purpose of the window is to present a display to the public.
- (d) In contact with the soil, in a depression below general ground level, or where potentially corrosive materials are likely to contact the meter set.
- (e) In poorly ventilated breezeways.
- (f) In crawl spaces under buildings or decks.
- (g) Near a driveway or other traveled areas, unless adequately protected from passing vehicles.

**Note: All meter locations are subject to GRU approval.**

5) Meter Set Regulator Vent Requirements.

Service regulator vents must terminate in a safe, well ventilated, outside location. The gas meter set must be installed so that the regulator vent shall not:

- (a) Terminate where there are any building openings within 18" the regulator vent to include the area beneath this 18" radius circle (see page 89 for detail).
- (b) Terminate within 36 inches of any source of ignition or within 10 ft of any forced air intake.
- (c) Terminate under building overhangs where the overhang is likely to direct venting gas into a building opening.
- (d) Terminate in poorly ventilated breezeways.
- (e) In instances of unusually restricted utility/equipment areas, please contact GRU to have a qualified person assist in locating gas and electric metering.

**7.4 Customer-Owned Gas Piping (Inside Gas Piping)**

- 1) GRU does not maintain customer-owned gas piping. The design and installation of customer-owned piping shall comply with the current issue of the "Florida Building Code", and the requirements of the governmental authorities having jurisdiction (City or County inspectors).



- 2) Plastic piping requires a minimum cover of 18 inches, a minimum of 12 inches cover is allowable if external damage to the pipe is not likely to result. Plastic piping shall not be used within or under any building or structure. Only qualified personnel may fuse plastic piping.
- 3) Gas service shall not be established to any premise unless all outlets are properly and securely connected to gas appliances, or capped in an appropriate manner. Only qualified persons should install customer-owned facilities. All customer-owned equipment, materials or appliances shall be installed in a manner that does not interfere with GRU service and metering equipment.
- 4) It is recommended that the installer prepare a piping layout for all new home installations where such a plan is not furnished by the architect or builder.
  - (a) Gas piping shall be sized in accordance with the current issue of the Florida Building Code (Fuel Gas) or other approved engineering methods acceptable to the authority having jurisdiction.
  - (b) In some instances, it may be economically advantageous to install a "2 PSIG Piping System". The design operating pressure for the "2 PSIG Piping System" is 2 PSIG from the outlet of the GRU meter through the house line to the house line regulator(s) (ex: Maxitrol Gas Appliance Regulator). All secondary regulation shall be supplied by the owner, contractor, or builder. The house line regulator(s) are typically located at the appliance(s) and will reduce the 2 PSIG pressure to "inches of water column" as required by the specific appliance(s). The house line regulator(s) must be approved to operate, at least up to 2 PSIG, and vented to the outdoors or be equipped with an approved vent-limited device. All "2 PSIG Piping System" and associated regulator(s) must be designed and installed according to the requirements of the manufacturer and the current "Florida Building Code".
  - (c) Pipe sizing is based on the fully connected load. The fully connected load can be obtained by totaling the name plate ratings of all the connected appliances. To convert BTU ratings to cubic feet, divide BTU rating by 1000. The minimum size for steel pipe is 1/2".
- 5) Testing and Inspection
  - (a) Prior to initial operation, all piping installations shall be inspected and tested to determine that the materials, design, fabrication and installation comply with the current issue of the "Florida Building Code" and the requirements of the governmental authorities having jurisdiction.
  - (b) In order to assure the gas piping is safely installed and free from leaks, it must be tested for tightness upon completion. The completed system will be tested with air as outlined in the current issue of the "Florida Building Code" and the requirements of the governmental authorities having jurisdiction. On existing installations where piping has been changed for any reason and air pressure is used for testing, the gas meter must be disconnected and removed during the test. For new installations, the meter will not be set until after the piping has been tested.
  - (c) Before gas is introduced into a piping system, the entire system will be checked to determine that there are no open fittings or ends and that all valves at outlets and equipment are closed. Service may be established only after the piping system has been tested and determined to be free from leakage. Immediately after introducing gas into the piping system, the system will be checked to determine that no gas is escaping.
    - 1-Under no circumstances shall any person test for leaking gas with a match or open flame.
  - (d) After the piping has been checked and the meter turned on, all gas piping shall be fully purged. Purging of gas piping shall comply with the current issue of the "Florida Building Code".

**TYPICAL RESIDENTIAL GAS INSTALLATION WITH ELECTRIC SERVICES**

**NOTES:**

- 1) Examples of ignition sources: some types of electric meters, air conditioners, pool heaters, all electric disconnect switches, fireplace vents, and others.
- 2) Please refer questions regarding meter sets to the GRU Gas and Electric Measurement Department.
- 3) The "Meter Zone" is typically 18" wide measured from the House Line stub-out to the Regulator Vent. The "Meter Zone" width will vary when multiple meters are installed. The meter is typically located on the left side of the House Line.
- 4) Please refer to the current edition of NFPA 58 "Liquid Petroleum Gas Code" for LP Gas venting requirements.

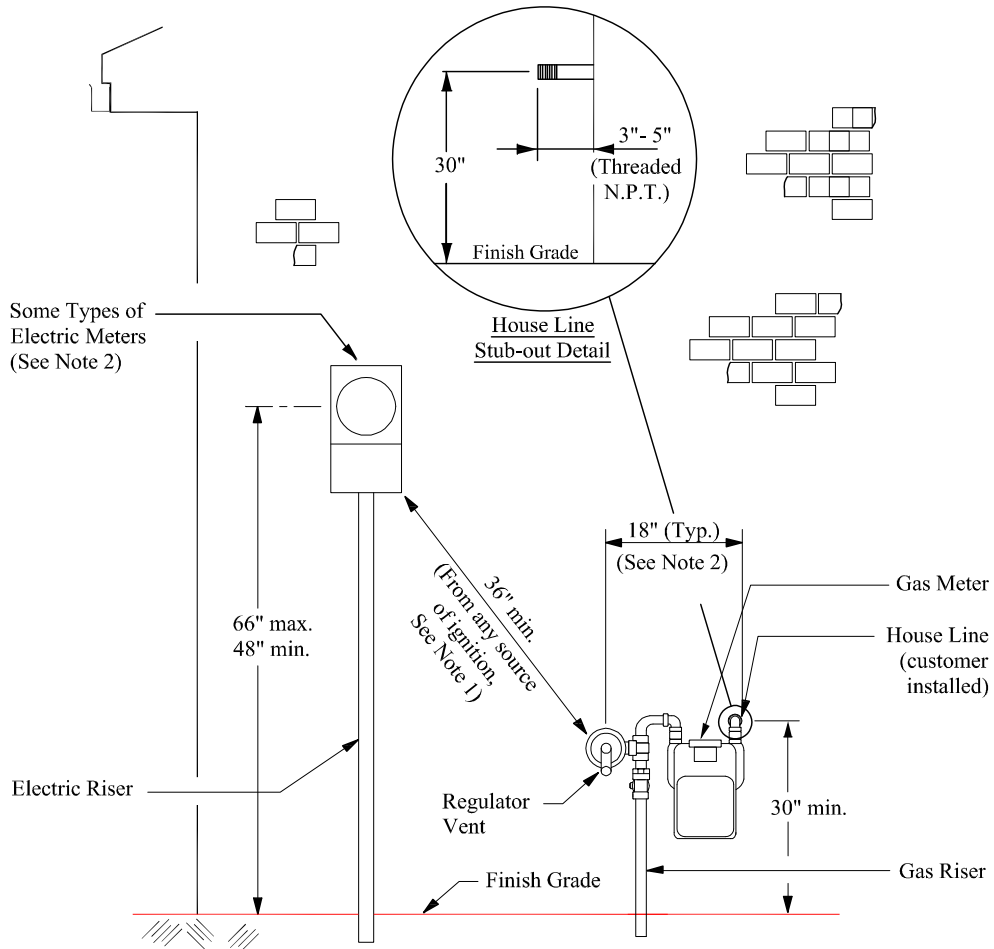

**TYPICAL RESIDENTIAL GAS INSTALLATION WITH AIR CONDITIONING EQUIPMENT**

**NOTES:**

- 1) Examples of ignition sources: some types of electric meters, air conditioners, pool heaters, all electric disconnect switches, fireplace vents, and others.
- 2) Please refer questions regarding meter sets to the GRU Gas and Electric Measurement Department.
- 3) The "Meter Zone" is typically 18" wide measured from the House Line stub-out to the Regulator Vent. The "Meter Zone" width will vary when multiple meters are installed. The meter is typically located on the left side of the House Line.
- 4) Please refer to the current edition of NFPA 58 "Liquid Petroleum Gas Code" for LP Gas venting requirements.

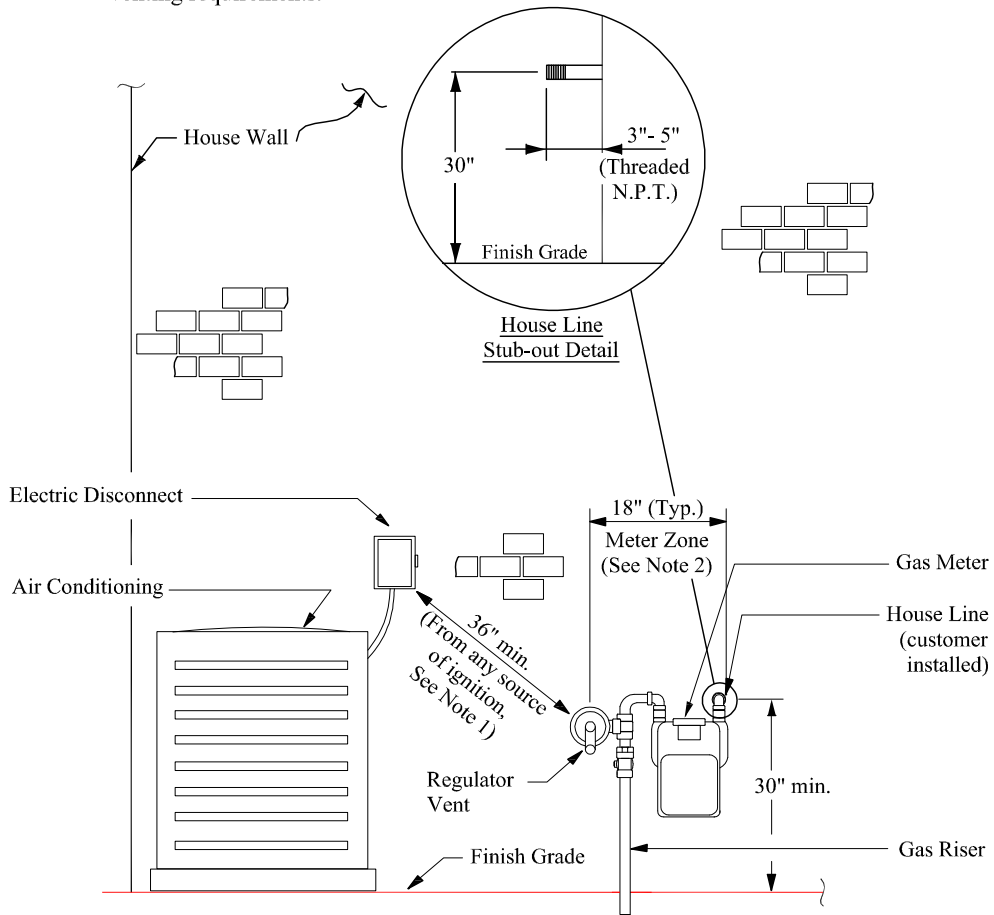

**TYPICAL RESIDENTIAL GAS INSTALLATION ON WALL WITH BUILDING OPENING**

NOTES:

- 1) The meter is typically located on the left side of the House Line.

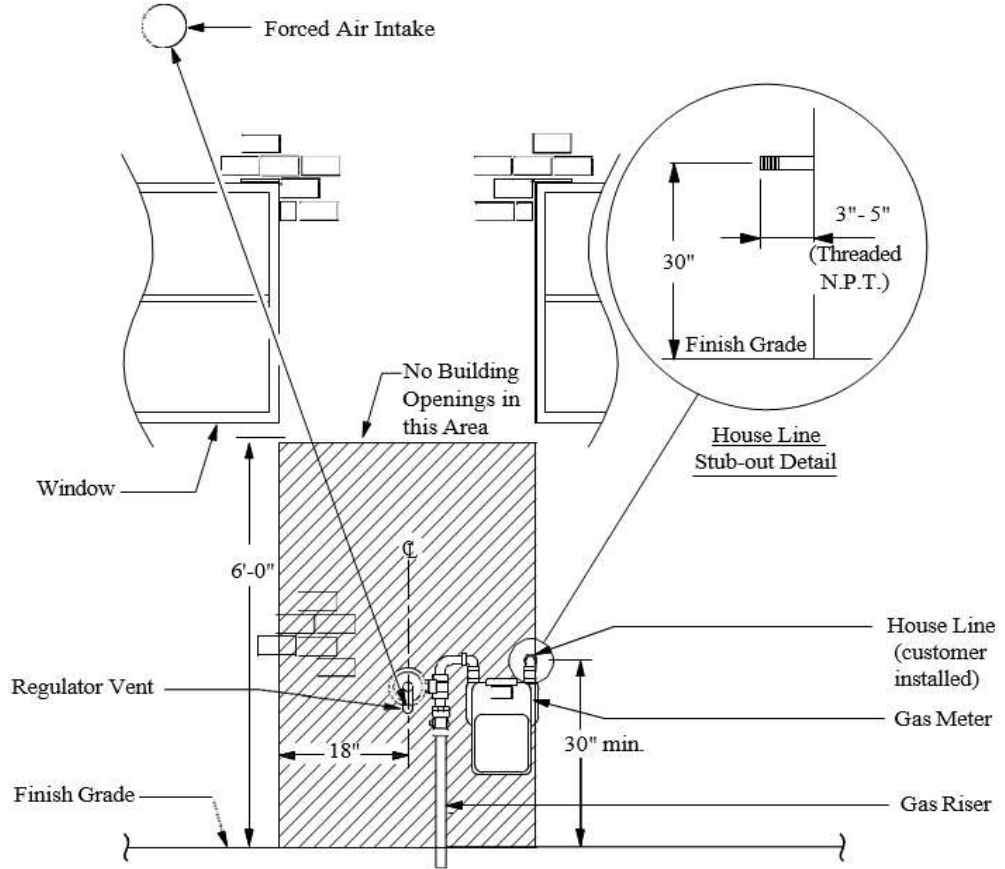

## GAS PIPING TRENCH DETAILS (TYP.)

### NOTE:

- 1) All Gas Service Piping shall be furnished and installed by GRU.  
House gas piping shall be furnished and installed by Owner.

### Roadway Trench

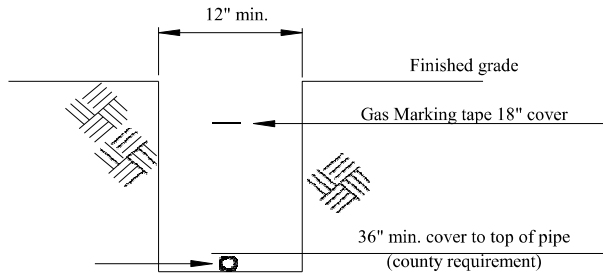

### Service Trench

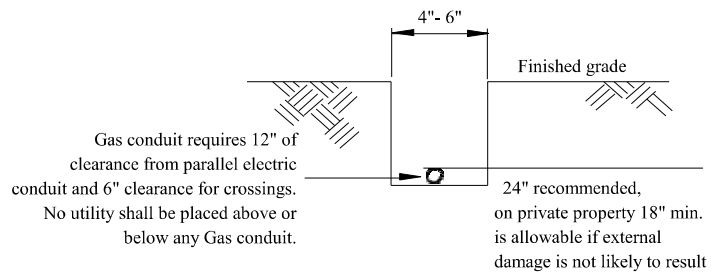

## Section 8: SOLAR ELECTRIC PHOTOVOLTAIC (PV) NET ENERGY METERING (NEM)

### 8.1 General

#### 1) Program Overview

- (a) The intent of the Net Energy Metering (NEM) Program is to provide a standard offer (non-negotiated) Interconnection Agreement (IA) to those wishing to install solar photovoltaic (PV) generation to displace the customer's utility purchased energy. Annually, the excess energy will be sold to Gainesville Regional Utilities (GRU) at the current avoided cost. The IA is not assignable. (Example of the IA is available on the GRU website)

Customers that submit a Letter of Intent to GRU to construct a photovoltaic solar system by April 17, 2024, and meet all requirements set forth in Gainesville Regional Utilities' Interconnection Agreement and Energy Delivery Service Guide, shall be compensated for excess energy delivered to GRU's distribution system as outlined in their Interconnection Agreement.

Customers that submit a Letter of Intent to GRU to construct a photovoltaic solar system on or after April 18, 2024, and produce excess energy that is delivered to GRU's distribution system, shall in each billing period receive GRU's then-current fuel adjustment rate for each kilowatt-hour that is provided to GRU's distribution system within that billing period.

#### 2) Eligibility

- (a) To be eligible to apply for the NEM Program, a solar photovoltaic project must lie within GRU's electric service territory and meet certain capacity restrictions. Both residential and non-residential customers are eligible for NEM.

#### 3) Participant Requirements

- (a) A signed and executed IA is required for participation in the NEM Program. Note that the system design must be approved by the GRU Energy Delivery Division (ED) before the IA may be executed. The IA contains terms and conditions related to requirements for interconnection to GRU's distribution system, operation of the facilities and insurance. The correct and current form of the IA will be posted on GRU's web site. Correspondence or inquires related to this program should be directed to the:

GRU Solar Program  
DL\_Solar@gru.com  
Phone: 352-393-1460

#### 4) GRU Photovoltaic Interconnection Guidelines

- (a) Approval for interconnecting a proposed PV generator to GRU's electric distribution system will normally be granted if the aggregated PV generation does not exceed 15% of a protected line section's annual peak load as determined by GRU. The calculated amount of PV generation is based on the DC rating of the PV system.
- (b) If the proposed PV generation causes the protected line section to exceed the 15% aggregated limit, then approval will not normally be granted. At the generator owner's request, GRU could initiate a system study funded by the generator owner to determine the possible impacts of the proposed generation to GRU electric distribution circuit. The review will take into consideration operation and engineering factors such as, but not limited to:
  - (1) Reverse power flow
  - (2) Voltage profiles
  - (3) System Protection Impacts
  - (4) Islanding

- (5) Fault Current Contribution
- (6) Any other impacts as determined by GRU (e.g. future load growth)
- (c) If review of the PV installation determines that GRU's distribution system will be adversely impacted the approval of the project will be denied unless acceptable mitigation solutions are possible as determined by GRU.
  - (d) Net metering shall mean a metering and billing methodology whereby customer-owned renewable generation is allowed to offset the customer's electricity consumption on site. Generation that is sized to exceed the customer's on site energy consumption will not be considered a net metering installation. The generation will be considered to be oversized if the kW DC rating of the PV generation is more than the average annual single account, on-site consumption (kWh) divided by 1393. (Note: Approximately 1 kW DC of PV generation will produce approximately 1393 kWh AC per year.) Also, the generation AC rating cannot exceed 90% of the utility transformer AC rating. GRU defines PV AC rating as 85% of the module's nameplate DC rating. In no event shall PV generation greater than 2 MW DC, at any one site, be allowed to interconnect under the net- metering program.
  - (e) The maximum amount of PV generation (total aggregated output of all PV generation interconnected to GRU's system) that can be interconnected on any of GRU's feeders shall not exceed 2 MW. Any individual project greater than 2 MW will require a dedicated feeder to a substation depending on the feasibility of constructing the dedicated feeder and/or substation expansion. If a dedicated feeder is approved the maximum PV generation shall not exceed 10 MW DC. GRU will make the final determination if a dedicated feeder and/or substation expansion is feasible.
  - (f) A single PV installation over 1.5 MW may require additional interconnection protection at the point of common coupling. This protection must be approved by GRU and paid in advance by the customer.
  - (g) The following conditions shall cause GRU to disconnect customer owned PV generation:
    - (1) Emergencies or maintenance requirements on GRU's electric distribution system.
    - (2) Adverse electrical effects, such as power quality problems, on GRU's electrical equipment, and/or GRU's customers.
    - (3) Hazardous conditions existing on GRU's electric distribution system due to the operation of the customer's PV installation.
  - (h) Single phase PV generation shall be connected at 240 volts. Connecting the PV system at 120 volts, at a single phase transformer will not be allowed.
  - (i) The output of the PV system shall be balanced between the three phases when interconnecting to a 3 phase transformer. The PV output shall be balanced so that the difference in current (amperes) between phases shall be 10% or less, as measured from the most heavily loaded phase to the least loaded phase. Single phase connection to a three phase transformer will not be allowed.
  - (j) A dedicated transformer may be required to interconnect PV generation with GRU's electric system. The cost of this modification will be paid in advance by the Customer.

- (k) The PV project shall be constructed and operated by the rules delineated in GRU's Energy Delivery Service Guide, Interconnection Agreement and SEPA documents and all other applicable codes.

## 8.2 Procedures

### 1) Documentation

A NEM owner must complete the following steps in order to qualify for NEM. (Samples of the required documentations are available on the GRU website) Submit a completed Letter of Intent. GRU will attempt to address all capacity request within 3 business days.

- (a) Receive approval of the project plan from GRU Energy Delivery Division;
- (b) Sign and execute the IA;
- (c) Any application fees will be added to the NEM owner's GRU bill.
- (d) Meet payment obligations for any GRU electrical distribution system upgrades that may be required to accommodate the PV system, if any;
- (e) Satisfy all applicable permitting, building code, planning and land use requirements;
- (f) Pass GRU's acceptance test and be interconnected to the distribution system;

### 2) Zoning, Land Use & GRU Approval Considerations

- (a) The NEM owner is solely responsible for understanding and observing all planning, zoning and land use regulations. The NEM owner is strongly encouraged to work with the city or county planning department to verify proper zoning and satisfy planning requirements as soon as possible. GRU is not liable for any delays due to city zoning or permitting issues.
- (b) The NEM owner (or contractor) is responsible for obtaining all necessary permits and for scheduling inspections applicable to the project in the political jurisdiction in which the project is located.
- (c) The NEM owner should contact GRU ED Engineering in a timely manner to discuss the project and schedule any necessary site visits. The GRU ED Engineering contact will review the NEM owner's drawings for compatibility with GRU's distribution system and will identify any distribution system upgrades required by the project. If any upgrades are identified, the NEM owner will receive an invoice listing equipment upgrades and the estimated costs associated with their project. No modifications to GRU's electrical distribution system will begin until these costs are paid in advance.
- (d) Each project is allotted up to eight (8) hours of engineering review. Review time in excess of eight (8) hours will be charged to the NEM owner at the applicable rate for GRU personnel.



## 8.3 Construction

### 1) GRU Construction Guide Lines:

- (a) It is the customer's responsibility to ensure the contractors and subcontractors adhere to GRU construction guidelines and follow all interconnection rules as stated in the IA and in the GRU Energy Delivery Service Guide. If there are any questions, please contact the GRU Customer Service Department at (352) 334-3434, and ask to speak with a Staff Assistant in the Energy Delivery Engineering Division or submit an email to DL Solar@gru.com.

### 2) Design Requirements

- (a) The following information shall be submitted to the DL Solar@gru.com:

- (1) A one-line electrical diagram is defined as "An electrical representation of the connectivity of the equipment used in the interconnection of the PV system to the customer's electrical system". This drawing should include name and address of both the customer and the solar contractor, total PV system size, type and size of conduits to be used, number and size of wires in each, rating of existing and new equipment including termination points within the meter sockets, listing of the required placards' wording with referencing location numbers, and an electric panel schedule showing the balancing of the strings per phase on a three phase PV system to within 10%.
  - (a) Customers should connect and balance loads so that the difference in amperes between phases will be 10% or less from the most heavily loaded phase to the least loaded phase.
  - (b) Connection of any privately owned power production source (solar, generators, batteries, wind, etc.) to a utility connected electrical system shall NOT be made, at any point in the system (load or line), by the use of self-piercing or insulation piercing taps.
- (2) An elevation drawing with a riser diagram is defined as "a real position view of the existing and proposed equipment showing conduit runs, windows, doors, and other utilities, such as phone and natural gas". The view should at least include all the AC components of the service entrance for the structure. If conduits leave the view through the wall or go underground, a note should be added to indicate the termination point(s) of these conduits.
- (3) A site plan, defined as a geographic representation of the location of the project. **NOTE: THIS IS ONLY REQUIRED FOR TIER 2 AND 3.** It should include a north arrow, the street name parcel is adjacent to, and the distance and name of the closest intersecting street. The position of the dwelling of the parcel should be provided (See 101, Section 8.5 for an example)
- (4) A panel array diagram is defined as "a layout of the location of the PV panels on the roof and/or ground mounting". **NOTE: THIS IS ONLY REQUIRED FOR TIER 2 & 3.** This document will be used for present and future auditing purposes. This information can be included in the site plan if preferred (See 101, Section 8.5 for an example)

### 3) Field Requirements

- (a) Due to this Interconnection being Interactive with the utility it is the requirement of GRU to have all wiring from the inverter, Auxiliary disconnect, and panel to meet applicable NEC requirements of a Service. This includes installation of service rated equipment. All wiring to be installed exposed to physical damage is required to be installed in a conduit rated for such by the NEC. Examples of the types of conduits required are RMC, IMC, Sch 80 PVC, and EMT. If deemed by the AHJ and/or a qualified GRU employee as not subject to physical damage PVC Sch 40 will be an approved alternative.

- (b) The Auxiliary Generation Disconnect shall be wired in accordance with the Energy Delivery Service guidelines. The top side (manufacturer labeled line side) wiring of the Auxiliary Generation Disconnect shall be connected to the feed from the NEM owner's wiring which is connected to GRU's electrical system and the bottom side (manufacturer labeled load side) wiring of the disconnect shall be connected to the PV array.
- (1) Any requests for deviations from listed requirements must be submitted in writing and shall be pre-approved by qualified GRU personnel. Additional warning placards may be required and must also be pre-approved by qualified GRU personnel.
  - (2) Installations that have instrument-rated metering shall require additional labeling as directed by qualified GRU personnel. A few examples would be,
    - (a) a label indicating the AC disconnect location,
    - (b) the CT's polarity mark should point toward the inverter (which is the source), etc.
  - (3) If an existing meter socket is used as a physical means of interconnection to the GRU system and it does not meet applicable/current NEC and GRU standards, the customer is responsible for installing a new revenue meter socket and other materials such as weatherhead, mast, service entrance conductors, etc. to meet these standards.
  - (4) Scheduled Service Interruptions, Reconnect Appointments, Installations of Bi-Directional Meter & REC Meter appointments
    - (a) Schedule the power disconnect/reconnect appointment with GRU at least 7 to 10 days before the disconnect/reconnect is required, by contacting GRU's Work Order Center at 352-393-1551.
    - (b) All re-connections will require approval by the authority having jurisdiction.
    - (c) All Bi-Directional Meter Installations will require the Solar Contractor to schedule an appointment with GRU's Gas & Electric measurement Department, by calling (352) 393-1505. At the time of this appointment it will be the Solar Contractor's responsibility to have a technician on-site within (15) minutes of the scheduled appointment so that all final checks can be completed by the Electric Measurement Technician. It is GRU's expectations that all equipment is ready for operation upon arrival and all required labels are installed on the equipment. At the time of the appointment the GRU representative will open the Revenue Meter Socket to allow the safe installation of the required label. Appointments are not to last more than 1 hr, if the Solar Contractor does not arrive at the scheduled time, the system is not complete, and ready for testing/interconnection the appointment will end and it will be the Contractor's responsibility to reschedule. At GRU's discretion charges may be applied for multiple field visits to the site.

## 8.4 Net-Metered PV Installation Requirements

- 1) Requirements — All requirements of GRU's Energy Delivery Service Guide must be met, at no time does this section alleviate the requirements previously established in other sections.
  - (a) The NEM owner shall install, at the NEM owner's expense, a manual disconnect device within ten (10) feet of the GRU revenue meter to provide a separation point between the AC power output of the PV system and any NEM owner wiring connected to GRU's electrical system. With the NEM owner wiring which is connected to GRU's electrical system to be terminated on the top side (manufacturer labeled line side) of this disconnect and the AC power output of the PV System terminated on the bottom side (manufacturer labeled load side).
  - (b) Installations that have instrument rated revenue meters shall require additional placard as directed by qualified GRU personnel.
  - (c) The manual disconnect device shall be mounted between the main distribution panel and the PV array, readily accessible to GRU personnel and capable of being locked in the open position with a GRU padlock.
  - (d) The disconnect device shall have an interrupting rating sufficient for the nominal circuit voltage and the current that is available at the line terminals of this equipment.
  - (e) When the size of the PV system precludes the use of the NEM owner's service entrance equipment as the connection point, an alternate design must be provided by the NEM owner and approved by GRU before installation.
  - (f) Meter sockets or metering cabinets shall not be used as junction boxes and pull boxes. It shall only be used as the termination point for the conductors that are to be metered in the associated socket or cabinet. All other wiring shall remain outside the respective metering compartment.
  - (g) The disconnect device must be clearly labeled "Auxiliary Generation Disconnect" and be readily visible to GRU personnel. The placard shall be permanently affixed to the disconnect device, and shall be red, weatherproof, with white block lettering in accordance with IA Section 3.6.2 (See page 99, Section 8.6 for an example)
  - (h) The NEM owner shall install, at the NEM owner's expense, on GRU revenue meter socket covers, a clearly labeled "Warning: Electric Shock Hazard. Do Not Touch Terminals. Terminals on both line and load side may be energized in the open position" readily visible to GRU personnel. The placards shall be permanently affixed to the cover, and shall be made of red, weatherproof, with white block lettering in accordance with IA Section 3.11 (See page 100, Section 8.6 for an example)
- 2) Net-Metered PV Sample Placards
  - (a) Example: Auxiliary Generation Disconnect (See example on page 99)
  - (b) Example: Electric Shock Hazard (See example on page 100)

## **8.5 Example of Site Plan Diagram**

0

(a) Example: Site Plan (include panel array diagram) (See example on page 10 )

Example: Auxiliary Generation Disconnect Placard



Example: Electric Shock Hazard Placard



**Example: Site plan (include panel array diagram)**



Brightside Solar Energy Company

**Information removed from this Energy Delivery Service Guide Section 8**

NOTE: The following information pertaining to the canceled FIT Program has been removed from this Energy Delivery Service Guide.

The SOLAR FEED IN TARIFF (FIT) APPLICATION

All Sample Forms pertaining to the FIT Program

The diagram: (d) SINGLE PHASE ONE LINE DIAGRAM - FIT PV Installation Only (Sample):

The diagram: (e) TYPICAL UNDERGROUND RISER DIAGRAM (Elevation Plan) (Sample):

The diagram: (f) TYPICAL OVERHEAD OR UNDERGROUND SITE PLAN (Sample):

The diagram: (g) TYPICAL OVERHEAD OR UNDERGROUND RISER PLAN (Elevation Plan) (Sample):

The diagram: (h) TYPICAL OVERHEAD SITE PLAN (Sample):

The diagram: (i) THREE PHASE ONE LINE DIAGRAM - FIT PV Installation Only (Sample):



This Page Intentionally Left Blank.

## **GLOSSARY**

Approved - Acceptable to a qualified Gainesville Regional Utilities employee (see Qualified Employee below).

City - City of Gainesville, Florida.

City of Gainesville Code of Ordinances - City of Gainesville, Florida municipal Code.

Commercial - Any customer planning to use electric service supplied by GRU that is not a Detached Single Family Residence. Also known as Non-Residential.

County - Alachua County, Florida.

Customer - The corporation, municipality, governmental agency, association, partnership or individual using or planning to use electric service supplied by GRU or the architect, engineer, electrical contractor or other person acting as the customer's agent.

Delta Connection - Connected so that one end of each of the windings of a three-phase transformer are connected in series for a closed circuit.

Demand - The average rate at which electric energy in kW, kVA or kVAR is consumed per 30 minute time interval.

Detached Single Family Residence - Any property having only one residential building, where both building and land are under common ownership, intended or designed for one family and having one facility for the preparation, storage and keeping of food for consumption within the building. For the purposes of this definition, zero lot line construction is included in this definition. Also known as Residential.

Developer - Any person or legal entity with ownership or control of a development who can contract with GRU for electric distribution facilities.

Development - A single parcel of land or contiguous parcels of land for which improvements or facilities construction are planned or in progress.

Distribution System - All materials and equipment utilized by GRU to provide electricity to customers throughout its service territory; the electricity supply system.

DGR - Distributed Generation Resource, is defined as a solar photovoltaic generation system and any reference to the "distribution system" will mean NEM Owner's Buyer's electrical distribution system which the NEM Owner Buyer operates pursuant to authority of its Charter, Ch. 90-394, Laws of Florida.

Engineering Division - The Electrical Engineering Division of Gainesville Regional Utilities.

## **GLOSSARY (CONTINUED)**

Easement –An interest in land, which gives one party the right to use or enjoy land owned by another party. GRU obtains different types of easements by various methods to install, operate, and maintain its utility facilities in order to provide or extend service to its customers. The easements GRU acquires include the right to trim and keep trimmed trees and undergrowth, which interfere with the safe operation of utility lines. No buildings, permanent structures or obstacles may be placed in the easement area as they would interfere with GRU’s ability to safely and properly maintain its lines. The types of things that would not be permitted in easement areas include pools, decking, brick walls, storage sheds, and of course, homes. Movable fences are generally permissible but the property owner would be expected to bear the cost of moving such a fence if it was necessary for the maintenance of a line. Types of easements that GRU may acquire include the following:

Metes and Bounds Easement- Easement rights granted over a defined area where utility facilities will be located on a property. “Metes and Bounds” is a system or method of describing land, real property or real estate by a surveyor by listing compass directions and distances of the boundaries. This results in a legal description of the defined easement area.

Blanket Easement - May cover an entire parcel of land, not only the specific location of a utility or utilities Easement rights granted over an entire parcel of land for a specific purpose such as the construction, operation, and maintenance of a specific utility, or the right of ingress/egress).

Platted Easement - Specific easements that are dedicated by the developer of a subdivision when it is originally created (“Platted”). Typically these easements are dedicated as “Public Utility Easements”. Public Utility Easements are set aside to provide public services, such as drainage, water, electric, sewer, cable TV, telephone, etc.

Final Grade Level - Ground level after all construction and landscaping has been completed.

Florida Building Code - The State of Florida mandated building code.

City of Gainesville Code of Ordinances - City of Gainesville, Florida municipal Code of Ordinances.

GEM Division - The Gas and Electric Meter and Measurement Division (GEM) of GRU responsible for installation and maintenance of gas and electric meters.

Grounded Conductor - A system or circuit conductor that is intentionally grounded.

Grounding Conductor - A conductor used to connect equipment or the grounded circuit of a wiring system to a grounding electrode.

GRU - An abbreviation for the City of Gainesville, Gainesville Regional Utilities, and its electric system.

High Voltage Service - Electrical Service greater than 600 volts.

Inspector - Person authorized by the City of Gainesville or Alachua County and licensed by the State of Florida to inspect and approve electrical installations.

Instrument Transformer - A transformer that reproduces in its secondary circuit, in a definite and known proportion, the voltage or current of its primary circuit, with the phase relation substantially preserved. Isolated - Not readily accessible without special means.

kVA- kilovolt-amperes.

## **GLOSSARY (CONTINUED)**

kW - kilowatts, a measure of electrical demand.

Low Voltage Service - Electrical service delivered at 600 volts or less, phase to phase.

National Electric Code (NEC) - The National Electrical Code, (ANSI/NFPA 70), as adopted by the State of Florida and adopted by the authority having jurisdiction in the GRU service territory. Future revisions of the National Electrical Code may change the requirements of the code or the references contained herein.

National Electric Safety Code (NESC) - The National Electrical Safety Code (ANSI/IEEE C2). As approved by the authority having jurisdiction.

National Fuel Gas Code (NFGC) - The National Fuel Gas Code (NFPA 54/ ANSI Z223.1). As approved by the authority having jurisdiction.

Non-Residential - Any customer planning to use electric service supplied by GRU that is not a Detached Single Family Residence. Also known as Commercial.

Phase Conductor - The conductors other than the neutral conductor in a single or three phase AC circuit, (if there is no neutral conductor then any conductor is a phase conductor).

Phase with Higher Voltage to Ground (a.k.a.: high leg, kitty leg, power leg and stinger) - The phase (of a 3-phase 4-wire open or closed delta system) measured to neutral (nominal of 208 volts) on a 120/240 volt base system.

Point of Delivery - Designated by GRU, this is the location of the electrical interconnection of GRU's wires, conductors, or other apparatus to those of the customer. This interconnection point defines the boundary of GRU's maintenance responsibility, also called the point of attachment or point of connection.

PUE or P.U.E. - Public Utility Easement

Qualified Employee - A Gainesville Regional Utilities employee or agent familiar with company safety rules and regulations and the construction, application and operation of the equipment involved.

Readily Accessible - Capable of being reached quickly, for operation, renewal, or inspection without climbing or removing obstacles.

Residential - Any property having only one residential building, where both building and land are under common ownership, intended or designed for one family and having one facility for the preparation, storage and keeping of food for consumption within the building. For the purposes of this definition, zero lot line construction is included in this definition. Also known as Detached Single Family Residence.

ROW or R.O.W. - Right-of-way

Service - The readiness and ability of GRU to furnish energy.

Secondary Conductors - The conductors for delivering energy from the electricity supply system to the wiring system of the premises served, and/or the wire(s) or cable(s) installed and maintained by GRU to deliver electricity from GRU's distribution system to the point of delivery.

Service Drop - The overhead service conductors from the last pole or other aerial support to and including the splices, if any, connecting to the service entrance conductors at the building or other structure.

Service Entrance/Conductors - All cable, conduit, weatherhead, and associated materials installed, maintained and owned by the customer to conduct electricity from the point of delivery to the meter socket and/or any other isolating device.

## **GLOSSARY (CONTINUED)**

Service Equipment - The necessary equipment, usually consisting of a circuit breaker or switch and fuses, and their accessories located near the point of entrance of supply conductors to a building or other structure or an otherwise defined area intended to constitute the main control and means of cut off of the supply.

Service Lateral (GRU owned) - The underground conductors between the utility source, including any risers at a pole or other structure from transformers, and the first point of connection to the residential service entrance conductors in a terminal box, meter socket or other enclosure with adequate space, inside or outside the building wall. Where there is no terminal box, meter socket or other enclosure with adequate space, the point of delivery shall be considered the point of entrance of the service conductor into the building.

Service Line - Gas piping provided by GRU.

Service Mast (Mast/Riser) - The rigid galvanized steel conduit that runs from the top of the meter socket to the weatherhead in an overhead fed meter.

Source - Point of origin for "service/secondary conductors", typically a pole, transformer, pedestal, or similar equipment.

Special Permission - The written consent of a qualified employee. (See definition of Qualified Employee).

Temporary Electric Service - Electric service for construction, fairs, exhibits and other similar temporary purposes. The term of temporary service shall not exceed one year, [See Gainesville Code, Section 27-251].

Underwriters Laboratories (UL) - An organization recognized by the NEC that is concerned with product evaluation and maintains periodic inspection of listed equipment or materials. A UL listing states either that the equipment or material meets appropriate designated standards or has been tested and found suitable for use in a specified manner.

Weatherproof - So constructed or protected that exposure to the weather will not interfere with safe and successful operation of electrical equipment.

Wye Connection - Connected so that one end of each of the windings of a three phase transformer is connected to a common neutral point, and the other end is connected to the appropriate line terminal.

## INDEX

Applying for service	7
Availability (Service)	7
Clearances	11-12, 14-20
Code Compliance	14
Development plans	62
Easements	11-12, 14-20
Gas Services	83
Generators	70-71
Lighting Services	79
Manufactured / Mobile Homes	42, 60-62
Metering Equipment	33-60
Mobile Home Parks	42, 60-62
Modifications	9
Motors	73
NEM (Net Energy Metering)	93-103
Overhead Secondary Service (Permanent)	24, 28
Overhead Secondary Service (Temporary)	9, 10, 26-27, 31, 63
Point of Service	8, 24
Private Property	11, 79, 82, 92
Public Lighting	79-82
Relocation, Modification or Removal of Existing Facilities	9
Rental Lighting	79-82
Secondary Service Conductors (#)	8, 23-26, 33, 41
Service Quality	10
Services at Secondary Voltages	23
Service Type	7, 24
Temporary Service	9, 10, 26-27, 31-32
Termination Enclosure	26, 63
Underground Service (Permanent)	25, 32, 43, 62, 63, 65-68
Underground Service (Temporary)	26-27, 32
Use of Service	9

This Page Intentionally Left Blank.



**Electric Service Area**  
City of Gainesville, Alachua County, Florida

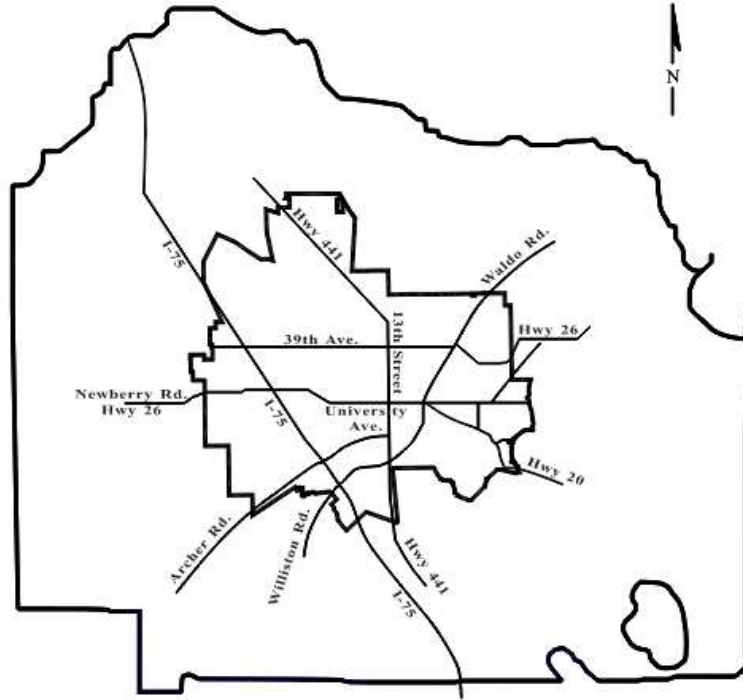

**Electric Service Area**  
(Subject to change. For exact Service Area contact GRU)